

AGILA TWIN

2970PJP075P30-10

EAN 4031582302721

Swivel castor, housing made of pressed steel, bright zinc plated, blue passivated, double ball bearing swivel head, wheel axle with nut, bolt hole. Wheel centre made of Polypropylene, Tread: TENTEprene (thermoplastic rubber), grey non-marking, precision ball bearing, with threadguards



BETTER MOBILITY. BETTER LIFE.



Picture may differ from original product

Technical Data

Wheel diameter	75 mm
Wheel width	25 mm
Castor width	71 mm
Centre hole	10,3 mm
Dome-Ø	65 mm
Offset	31.4 mm
Swivel Interference	145 mm
Overall height	99 mm
Temperature	- 20 / + 60 °C
Standard	EN 12530
Weight	0.523 kg
Swivel Radius	72.5 mm
Hardness of tread	Shore A 87
Load capacity	100 kg
Load capacity (static)	200 kg

Advantages at a glance

Roll performance	● ● ● ○ ○
Movement noise	● ● ● ○ ○
Attrition	● ● ● ○ ○
Corrosion resistance	● ● ● ○ ○

Dimensions

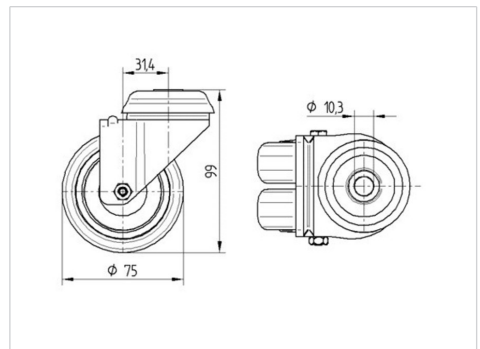

Structure & Mounting

