

# AGILA TWIN

2970UAK050P40

EAN 4031582302752

Drejelige hjul, Gaffel fremstillet af presset stål, forzinket, blåpassiveret, drejekrans med dobbelt kuglekrans, hjulaksel med møtrik, befæstigelsesplade. Hjulfælg: Polyamid, Hjulbane: Polyuretan, med trådfang, konuskugleleje



BETTER MOBILITY. BETTER LIFE.



Illustrationen kan afvige fra originalen

## Tekniske data

Hjul-Ø	50 mm
Hjulbredde	20 mm
Hjulbredde	53 mm
Plademål	60 x 60 mm
Hulafstand	48/38 x 48/38 mm
Pladehul-Ø	6,3 mm
DOM-Ø	53 mm
Udladning	25 mm
Udfalddiameter	106 mm
Byggehøjde	69 mm
Temperaturinterval	- 25 / - 25 °C
Standard	EN 12530
Vægt	0.305 kg
Udfalddradius	53 mm
Hjulbane hårdhed	Shore D 42
Belastning (dynamisk)	70 kg
Belastning (statisk)	140 kg

## Egenskaber/fordele

Rullemodstand	● ● ● ○ ○
Kørselsstøj	● ● ● ○ ○
Slid	● ● ● ● ○
Rustbeskyttelse	● ● ● ○ ○

## Dimensioner

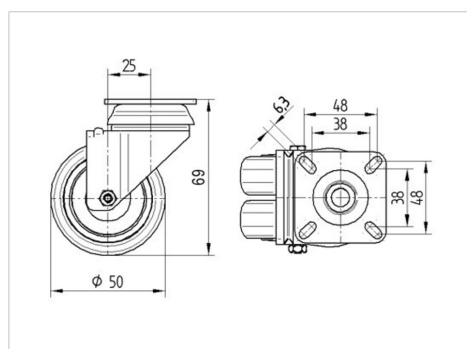

## Struktur og montering

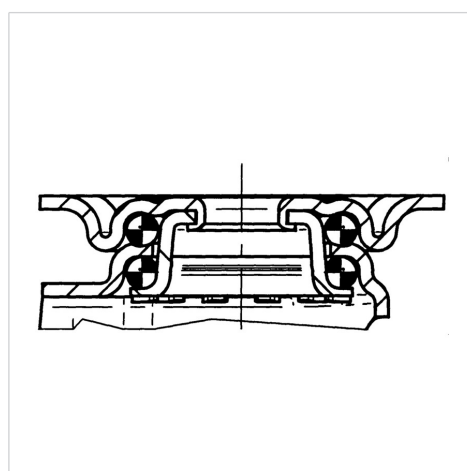

# AGILA TWIN

2970UAK050P40

EAN 4031582302752



BETTER MOBILITY. BETTER LIFE.

## Struktur og montering

