

AGILA TWIN

2970UAK050P40

EAN 4031582302752

Swivel caster, housing made of pressed steel, bright zinc plated, blue passivated, double ball bearing swivel head, wheel axle with nut, plate fitting. Wheel center made of Polyamide, Tread: Polyurethane, with threadguards, cone ball bearing



BETTER MOBILITY. BETTER LIFE.



Picture may differ from original product

Technical Data

Wheel diameter	50 mm
Wheel width	20 mm
Caster width	53 mm
Plate size	60 x 60 mm
Plate hole centers	48/38 x 48/38 mm
Plate hole	6,3 mm
Dome-Ø	53 mm
Offset	25 mm
Swivel Interference	106 mm
Overall height	69 mm
Temperature	- 25 / - 25 °C
Standard	EN 12530
Weight	0.305 kg
Swivel Radius	53 mm
Hardness of tread	Shore D 42
Load capacity (dynamic)	70 kg
Load capacity (static)	140 kg

Dimensions

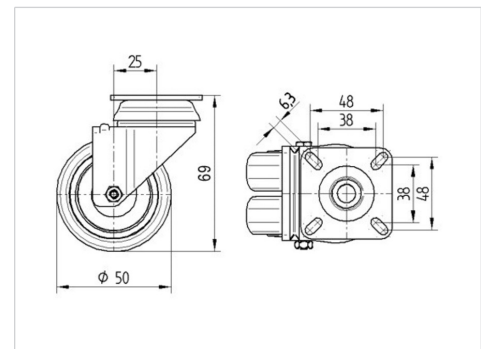

Structure & Mounting

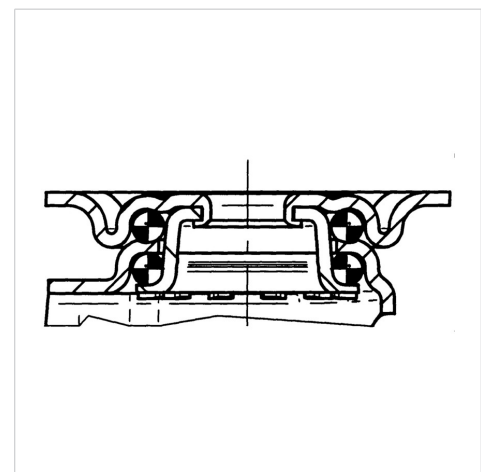

Advantages at a glance

Roll performance	● ● ● ○ ○
Movement noise	● ● ● ○ ○
Attrition	● ● ● ● ○
Corrosion resistance	● ● ● ○ ○

AGILA TWIN

2970UAK050P40

EAN 4031582302752



BETTER MOBILITY. BETTER LIFE.

Structure & Mounting

