

# AGILA TWIN

2976PJH075P54

EAN 4031582302875

Swivel caster with central lock, housing made of pressed steel, bright zinc plated, blue passivated, double ball bearing swivel head, wheel axle with nut, Stainless Steel balls, plate fitting. Wheel center made of Polypropylene, Tread: TENTEprene (thermoplastic rubber), grey non-marking, with threadguards, plain bearing



BETTER MOBILITY. BETTER LIFE.



Picture may differ from original product

## Technical Data

Wheel diameter	75 mm
Wheel width	25 mm
Caster width	71 mm
Plate size	70 x 55 mm
Plate hole centers	57/51 x 41 mm
Plate hole	5,5 mm
Dome-Ø	65 mm
Offset	28 mm
Swivel Interference	131 mm
Overall height	103 mm
Temperature	- 20 / + 60 °C
Standard	EN 12530
Weight	0.58 kg
Swivel Radius	65.5 mm
Hardness of tread	Shore A 87
Load capacity (dynamic)	100 kg
Load capacity (static)	200 kg

## Dimensions

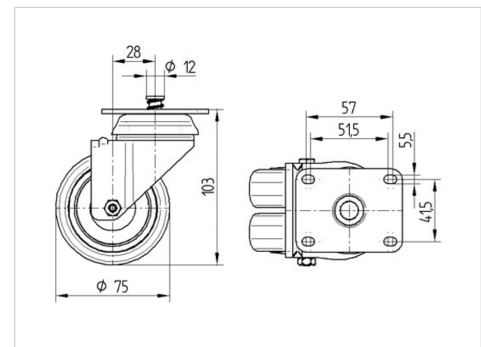

## Structure & Mounting

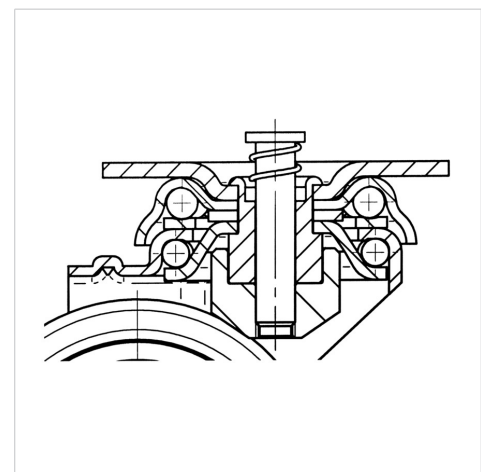

## Advantages at a glance

Roll performance	● ● ● ○ ○
Movement noise	● ● ● ○ ○
Attrition	● ● ● ○ ○
Corrosion resistance	● ● ● ○ ○

# AGILA TWIN

2976PJH075P54

EAN 4031582302875



BETTER MOBILITY. BETTER LIFE.

## Structure & Mounting

