

# AGILA TWIN

2977DIK075P50

EAN 4031582302905

Swivel castor with total lock, tail end of castor, housing made of pressed steel, bright zinc plated, blue passivated, double ball bearing swivel head, wheel axle with nut, plate fitting. Wheel centre made of pressed steel, Tread: solid rubber, grey non-marking, with threadguards, cone ball bearing



BETTER MOBILITY. BETTER LIFE.



Picture may differ from original product

## Technical Data

Wheel diameter	75 mm
Wheel width	25 mm
Castor width	71 mm
Size of Plate	77 x 67 mm
Plate hole centres	61,5/56 x 51,5/46,5 mm
Plate hole	8,5 mm
Dome-Ø	65 mm
Offset	31.3 mm
Swivel Interference	198 mm
Overall height	102 mm
Temperature	- 20 / + 85 °C
Standard	EN 12530
Weight	0.98 kg
Swivel Radius	99 mm
Hardness of tread	Shore A 80
Load capacity	100 kg
Load capacity (static)	200 kg

## Advantages at a glance

Roll performance	● ● ● ○ ○
Movement noise	● ● ● ○ ○
Attrition	● ● ● ○ ○
Corrosion resistance	● ● ● ○ ○

## Dimensions

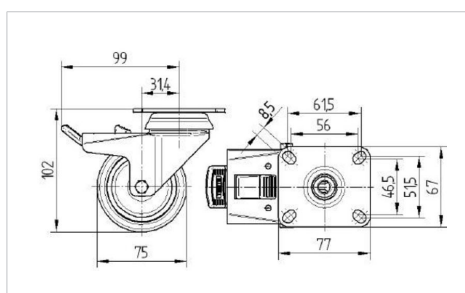

## Structure & Mounting

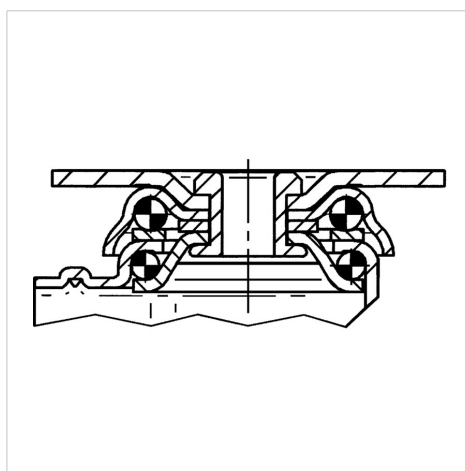

# AGILA TWIN

2977DIK075P50

EAN 4031582302905



BETTER MOBILITY. BETTER LIFE.

## Structure & Mounting

