

AGILA TWIN

2977PJP075P30-10

EAN 4031582302936

Swivel caster with total lock, trailing end of caster, housing made of pressed steel, bright zinc plated, blue passivated, double ball bearing swivel head, wheel axle with nut, bolt hole. Wheel center made of Polypropylene, Tread: TENTEprene (thermoplastic rubber), grey non-marking, precision ball bearing, with threadguards



BETTER MOBILITY. BETTER LIFE.



Picture may differ from original product

Technical Data

Wheel diameter	75 mm
Wheel width	25 mm
Caster width	71 mm
Center hole	10,3 mm
Dome-Ø	65 mm
Offset	31.3 mm
Swivel Interference	198 mm
Overall height	99 mm
Temperature	- 20 / + 60 °C
Standard	EN 12530
Weight	0.635 kg
Swivel Radius	99 mm
Hardness of tread	Shore A 87
Load capacity (dynamic)	100 kg
Load capacity (static)	200 kg

Dimensions

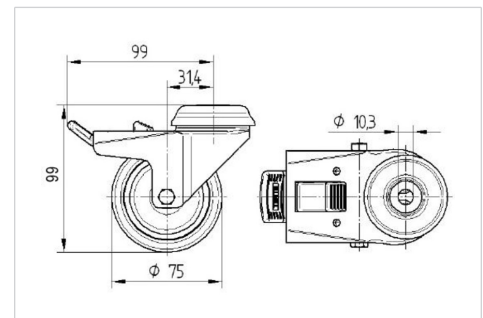

Structure & Mounting

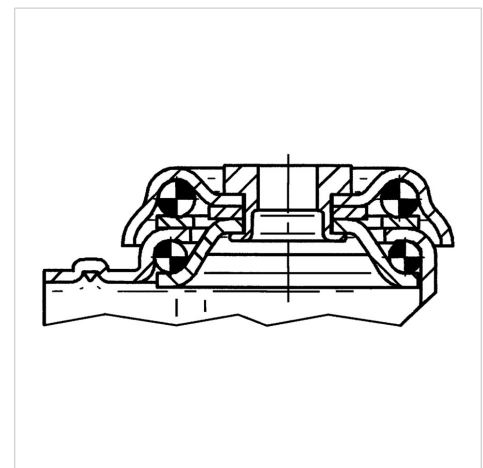

Advantages at a glance

Roll performance	● ● ● ○ ○
Movement noise	● ● ● ○ ○
Attrition	● ● ● ○ ○
Corrosion resistance	● ● ● ○ ○