

# ALPHA

3470ITP125P63

EAN 4031582303704

Swivel castor, housing made of pressed steel, bright zinc plated, blue passivated, double ball bearing swivel head, wheel axle with nut, dustguard, plate fitting. Wheel centre made of Aluminium, Tread: Polyurethane, casted, precision ball bearing



BETTER MOBILITY. BETTER LIFE.



Picture may differ from original product

## Technical Data

Wheel diameter	125 mm
Wheel width	50 mm
Castor width	96 mm
Size of Plate	137 x 105 mm
Plate hole centres	105 x 80/75 mm
Plate hole	11 mm
Dome-Ø	96 mm
Offset	55 mm
Swivel Interference	235 mm
Overall height	161 mm
Temperature	- 10 / + 60 °C
Standard	EN 12532
Weight	2.153 kg
Swivel Radius	117.5 mm
Hardness of tread	Shore A 67
Load capacity	300 kg
Load capacity (static)	600 kg

## Advantages at a glance

Roll performance	● ● ● ○ ○
Movement noise	● ● ● ○ ○
Attrition	● ● ● ● ○
Corrosion resistance	● ● ● ○ ○

## Dimensions

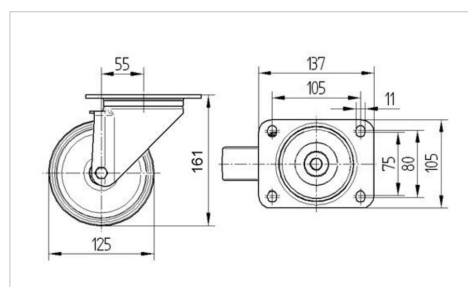

## Structure & Mounting

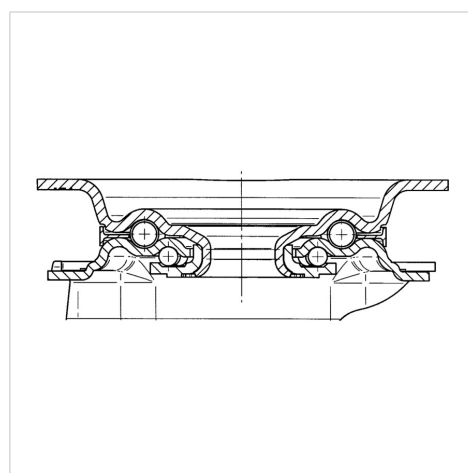

# ALPHA

3470ITP125P63

EAN 4031582303704



BETTER MOBILITY. BETTER LIFE.

## Structure & Mounting

