

# ALPHA

3471PVR160P63

EAN 4031582304824

Swivel castor with directional lock, housing made of pressed steel, bright zinc plated, blue passivated, double ball bearing swivel head, wheel axle with nut, dustguard, plate fitting. Wheel centre made of Polypropylene, Tread: solid rubber, black, roller bearing

**Hint:**

This castor can be fitted with a directional lock. However, the lock does not come as standard and has to be ordered as an optional extra.



BETTER MOBILITY. BETTER LIFE.



Picture may differ from original product

**Technical Data**

Wheel diameter	160 mm
Wheel width	40 mm
Size of Plate	137 x 105 mm
Plate hole centres	105 x 80/75 mm
Plate hole	11 mm
Offset	55 mm
Swivel Interference	270 mm
Overall height	200 mm
Temperature	- 20 / + 60 °C
Standard	EN 12532
Weight	2.035 kg
Swivel Radius	135 mm
Hardness of tread	Shore A 85
Load capacity	135 kg
Load capacity (static)	270 kg

**Dimensions**

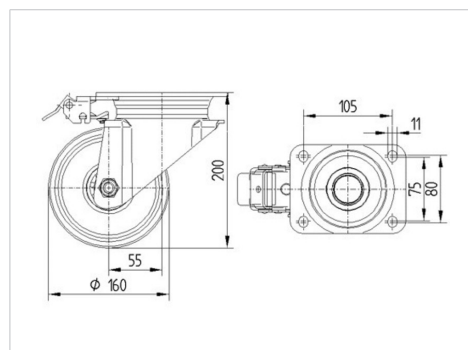

**Structure & Mounting**

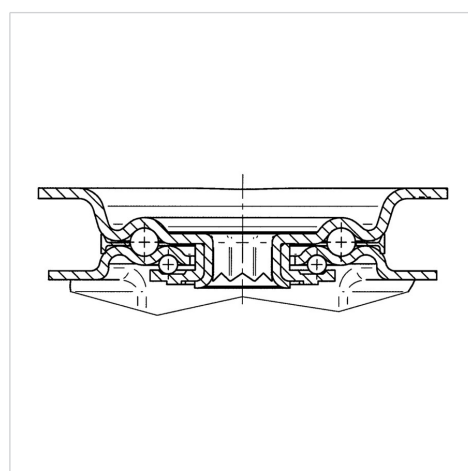

**Advantages at a glance**

Roll performance	● ● ● ○ ○
Movement noise	● ● ● ○ ○
Attrition	● ● ○ ○ ○
Corrosion resistance	● ● ● ○ ○

# ALPHA

3471PVR160P63

EAN 4031582304824



BETTER MOBILITY. BETTER LIFE.

## Structure & Mounting

