

ALPHA

3472PXU200P63

EAN 4031582304947

Swivel castor with total lock, head end of castor, housing made of pressed steel, bright zinc plated, blue passivated, double ball bearing swivel head, wheel axle with nut, dustguard, plate fitting. Wheel centre made of Polypropylene, Tread: solid rubber, black, with synthetic plain bearing. This castor meets the regulations for mobile waste containers according to DIN EN 840-5 and RAL-GZ 951/1 (SKZ-Certificate No. 116/03).



BETTER MOBILITY. BETTER LIFE.



Picture may differ from original product

Technical Data

Wheel diameter	200 mm
Wheel width	50 mm
Size of Plate	137 x 105 mm
Plate hole centres	105 x 80/75 mm
Plate hole	11 mm
Offset	55 mm
Swivel Interference	310 mm
Overall height	240 mm
Temperature	- 20 / + 60 °C
Standard	EN 12532
Weight	2.797 kg
Hardness of tread	Shore A 85
Load capacity	205 kg
Load capacity (static)	410 kg

Advantages at a glance

Roll performance	● ● ● ○ ○
Movement noise	● ● ● ○ ○
Attrition	● ● ○ ○ ○
Corrosion resistance	● ● ● ○ ○

Dimensions

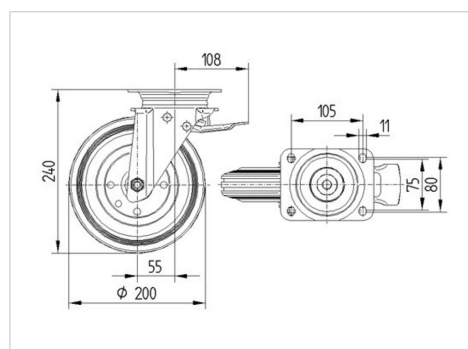

Structure & Mounting

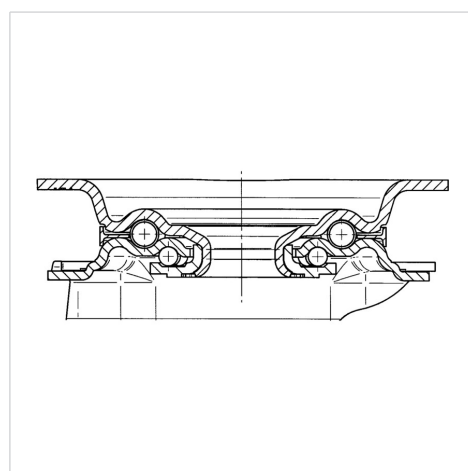

ALPHA

3472PXU200P63

EAN 4031582304947



BETTER MOBILITY. BETTER LIFE.

Structure & Mounting

