

ALPHA

3472PXU200P63

EAN 4031582304947

Swivel caster with total lock, leading end of caster, housing made of pressed steel, bright zinc plated, blue passivated, double ball bearing swivel head, wheel axle with nut, dustguard, plate fitting. Wheel center made of Polypropylene, Tread: solid rubber, black, with synthetic plain bearing This caster meets the regulations for mobile waste containers according to DIN EN 840-5 and RAL-GZ 951/1 (SKZ-Certificate No. 116/03).



BETTER MOBILITY. BETTER LIFE.



Picture may differ from original product

Technical Data

Wheel diameter	200 mm
Wheel width	50 mm
Plate size	137 x 105 mm
Plate hole centers	105 x 80/75 mm
Plate hole	11 mm
Offset	55 mm
Swivel Interference	310 mm
Overall height	240 mm
Temperature	- 20 / + 60 °C
Standard	EN 12532
Weight	2.797 kg
Hardness of tread	Shore A 85
Load capacity (dynamic)	205 kg
Load capacity (static)	410 kg

Advantages at a glance

Roll performance	● ● ● ○ ○
Movement noise	● ● ● ○ ○
Attrition	● ● ○ ○ ○
Corrosion resistance	● ● ● ○ ○

Dimensions

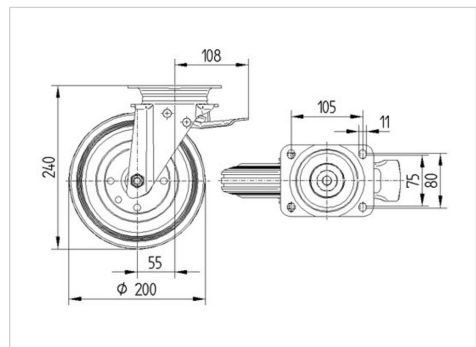

Structure & Mounting

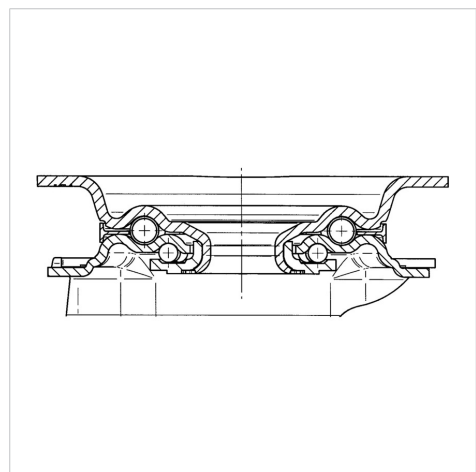

ALPHA

3472PXU200P63

EAN 4031582304947



BETTER MOBILITY. BETTER LIFE.

Structure & Mounting

