

# INTEGRAL TWIN

3940UAP150R05-32

EAN 4031582355062

Swivel castor, frame made of pressed steel, precision ball bearing in swivel head, housing with synthetic cover, solid plug fitting. Wheel centre made of Polyamide, Tread: Polyurethane, precision ball bearing



BETTER MOBILITY. BETTER LIFE.



Picture may differ from original product

## Technical Data

Wheel diameter	150 mm
Wheel width	15 mm
Castor width	74.5 mm
Bolt-Ø	32 mm
Bolt length	45 mm
Offset	45 mm
Swivel Interference	240 mm
Overall height	193 mm
Temperature	- 30 / + 80 °C
Standard	EN 12531 (load capacity)
Swivel Radius	120 mm
Hardness of tread	Shore D 40
Load capacity	250 kg
Load capacity (static)	750 kg

## Structure & Mounting

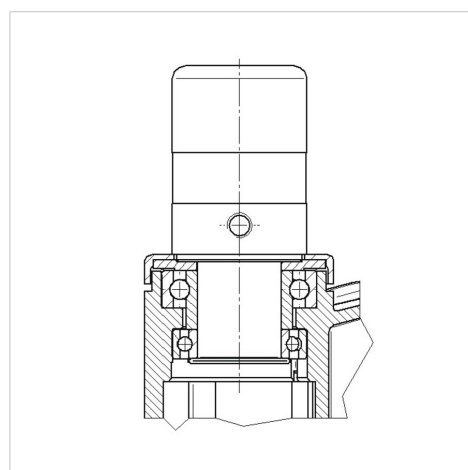

## Advantages at a glance

Roll performance	● ● ● ○ ○
Movement noise	● ● ● ○ ○
Attrition	● ● ● ● ○
Corrosion resistance	● ● ● ○ ○