

# ZETA

## 4680IEP125P63

EAN 4031582307795

Swivel castor, housing made of very heavy pressed steel, reinforced, bright zinc plated, blue passivated, sealed swivel double ball bearing, reinforced and heat-treated ball covers, riveted king pin, dust ring with integrated grease nipple, wheel axle with nut, plate fitting. Wheel centre made of Aluminium, Tread: black elastic-tyre, vulcanized, precision ball bearing



BETTER MOBILITY. BETTER LIFE.



Picture may differ from original product

### Technical Data

Wheel diameter	125 mm
Wheel width	50 mm
Castor width	96 mm
Size of Plate	137 x 105 mm
Plate hole centres	105 x 80/75 mm
Plate hole	11 mm
Dome-Ø	96 mm
Offset	55 mm
Swivel Interference	235 mm
Overall height	164 mm
Temperature	- 20 / + 85 °C
Standard	EN 12532
Weight	2.868 kg
Swivel Radius	117.5 mm
Hardness of tread	Shore A 67
Load capacity	300 kg
Load capacity (static)	600 kg

### Dimensions

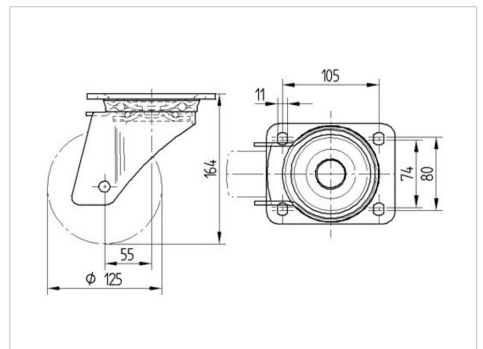

### Structure & Mounting

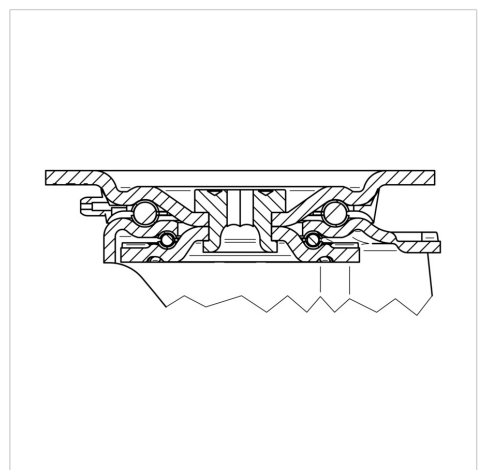

### Advantages at a glance

Roll performance	● ● ● ○ ○
Movement noise	● ● ● ○ ○
Attrition	● ● ● ○ ○
Corrosion resistance	● ● ● ○ ○

# ZETA

4680IEP125P63

EAN 4031582307795



BETTER MOBILITY. BETTER LIFE.

## Structure & Mounting

