

# ZETA

## 4681ITP250P63 Flat

EAN 4031582308006

Swivel castor with directional lock, housing made of very heavy pressed steel, reinforced, bright zinc plated, blue passivated, sealed swivel double ball bearing, reinforced and heat-treated ball covers, riveted king pin, dust ring with integrated grease nipple, wheel axle with nut, plate fitting. Wheel centre made of Aluminium, Tread: Polyurethane, casted, precision ball bearing



BETTER MOBILITY. BETTER LIFE.



Picture may differ from original product

### Technical Data

Wheel diameter	250 mm
Wheel width	55 mm
Castor width	96 mm
Size of Plate	137 x 105 mm
Plate hole centres	105 x 80/75 mm
Plate hole	11 mm
Dome-Ø	96 mm
Offset	55 mm
Swivel Interference	360 mm
Overall height	290 mm
Temperature	- 10 / + 60 °C
Standard	EN 12532
Weight	4.802 kg
Swivel Radius	180 mm
Hardness of tread	Shore D 42
Load capacity	800 kg
Load capacity (static)	1600 kg

### Dimensions

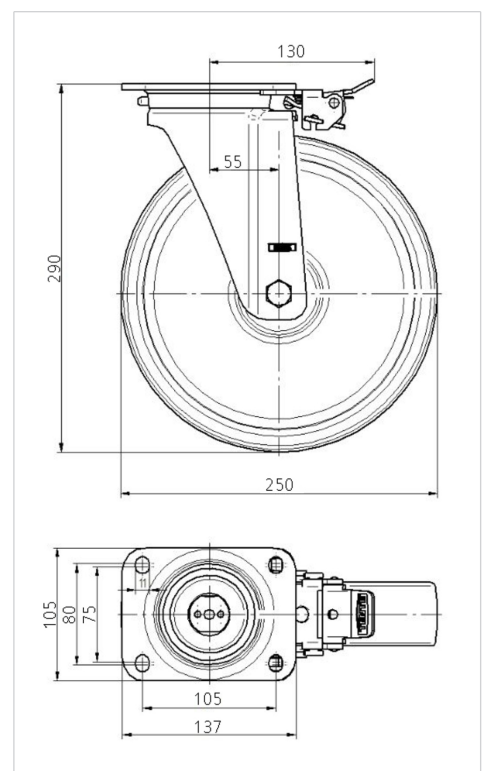

### Advantages at a glance

Roll performance	● ● ● ○ ○
Movement noise	● ● ● ○ ○
Attrition	● ● ● ● ○
Corrosion resistance	● ● ● ○ ○

### Structure & Mounting

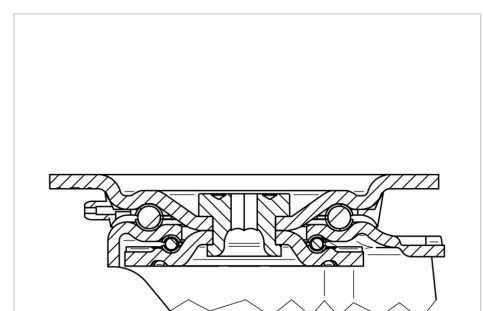

# ZETA

## 4681ITP250P63 Flat

EAN 4031582308006



BETTER MOBILITY. BETTER LIFE.

### Structure & Mounting

