

ZETA

4687ITP160P63 Flat

EAN 4031582050578

Swivel castor with total lock, tail end of castor, housing made of very heavy pressed steel, reinforced, bright zinc plated, blue passivated, sealed swivel double ball bearing, reinforced and heat-treated ball covers, riveted king pin, dust ring with integrated grease nipple, wheel axle with nut, plate fitting. Wheel centre made of Aluminium, Tread: Polyurethane, casted, precision ball bearing



BETTER MOBILITY. BETTER LIFE.



Picture may differ from original product

Technical Data

| | |
|------------------------|----------------|
| Wheel diameter | 160 mm |
| Wheel width | 50 mm |
| Castor width | 96 mm |
| Size of Plate | 137 x 105 mm |
| Plate hole centres | 105 x 80/75 mm |
| Plate hole | 11 mm |
| Dome-Ø | 96 mm |
| Offset | 55 mm |
| Swivel Interference | 322 mm |
| Overall height | 200 mm |
| Temperature | - 10 / + 60 °C |
| Standard | EN 12532 |
| Weight | 3.449 kg |
| Swivel Radius | 161 mm |
| Hardness of tread | Shore D 42 |
| Load capacity | 800 kg |
| Load capacity (static) | 1600 kg |

Advantages at a glance

| | |
|----------------------|-----------|
| Roll performance | ● ● ● ○ ○ |
| Movement noise | ● ● ● ○ ○ |
| Attrition | ● ● ● ● ○ |
| Corrosion resistance | ● ● ● ○ ○ |

Dimensions

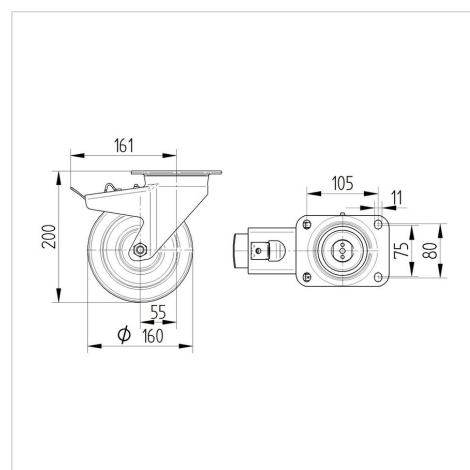

Structure & Mounting

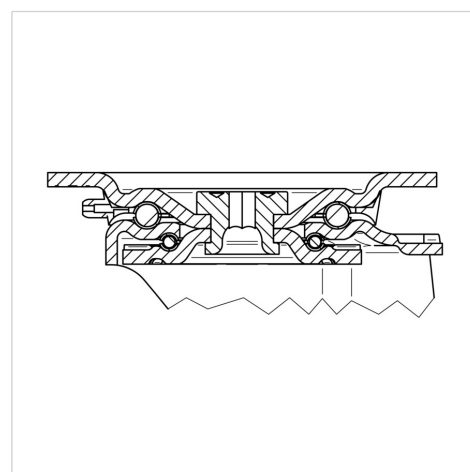

ZETA

4687ITP160P63 Flat

EAN 4031582050578



BETTER MOBILITY. BETTER LIFE.

Structure & Mounting

