

# ZETA

## 468BIEP160P63 180°

EAN 4031582398076

Swivel castor with automatic directional stability with total lock, housing made of very heavy pressed steel, reinforced, bright zinc plated, blue passivated, sealed swivel double ball bearing, reinforced and heat-treated ball covers, riveted king pin, dust ring with integrated grease nipple, wheel axle with nut, plate fitting. Wheel centre made of Aluminium, Tread: black elastic-tyre, vulcanized, precision ball bearing



BETTER MOBILITY. BETTER LIFE.



Picture may differ from original product

### Technical Data

Wheel diameter	160 mm
Wheel width	50 mm
Castor width	96 mm
Size of Plate	137 x 105 mm
Plate hole centres	105 x 80/75 mm
Plate hole	11 mm
Dome-Ø	96 mm
Offset	55 mm
Swivel Interference	360 mm
Overall height	200 mm
Temperature	- 20 / + 85 °C
Standard	EN 12532
Weight	3.715 kg
Hardness of tread	Shore A 67
Load capacity	350 kg
Load capacity (static)	700 kg

### Advantages at a glance

Roll performance	● ● ● ○ ○
Movement noise	● ● ● ● ○
Attrition	● ● ● ○ ○
Corrosion resistance	● ● ● ○ ○

### Dimensions

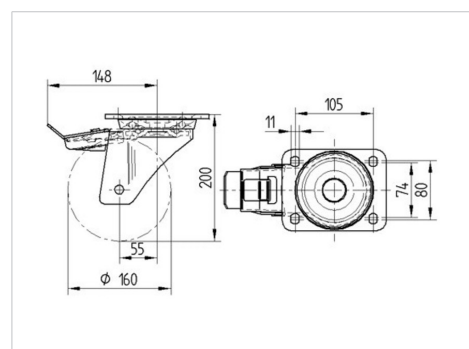

### Structure & Mounting

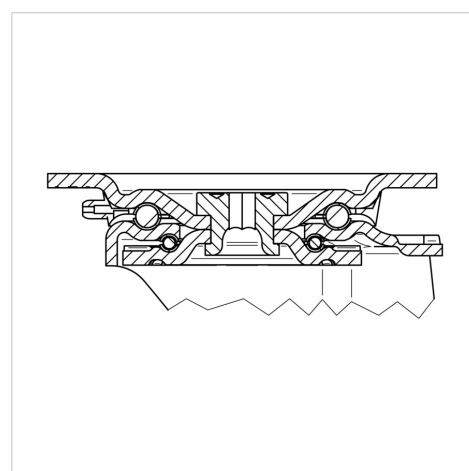

# ZETA

468BIEP160P63 180°

EAN 4031582398076



BETTER MOBILITY. BETTER LIFE.

## Structure & Mounting

