

# ZETA

468STOO160P63 180°

EAN 4031582398168

Swivel caster with spring loaded directional lock, housing made of very heavy pressed steel, reinforced, bright zinc plated, blue passivated, sealed swivel double ball bearing, reinforced and heat-treated ball covers, riveted king pin, wheel axle with nut and dust ring with integrated grease nipple., plate fitting. Wheel center made of Polyamide, heavy duty, plain bearing



BETTER MOBILITY. BETTER LIFE.



Picture may differ from original product

## Technical Data

Wheel diameter	160 mm
Wheel width	50 mm
Plate size	137 x 105 mm
Plate hole centers	105 x 80/75 mm
Plate hole	11 mm
Offset	55 mm
Swivel Interference	270 mm
Overall height	200 mm
Temperature	- 40 / + 80 °C
Standard	EN 12532
Weight	3.055 kg
Swivel Radius	135 mm
Hardness of tread	Shore D 75
Load capacity (dynamic)	800 kg
Load capacity (static)	1600 kg

## Dimensions

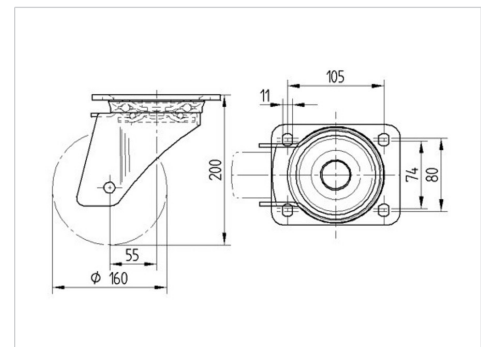

## Structure & Mounting

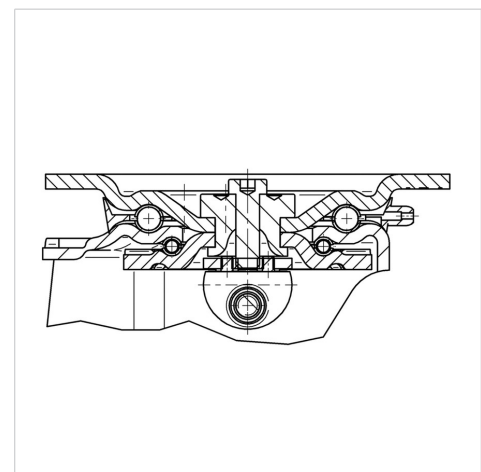

## Advantages at a glance

Roll performance	● ● ● ● ○
Movement noise	● ○ ○ ○ ○
Attrition	● ● ● ● ●
Corrosion resistance	● ● ● ○ ○

# ZETA

468STOO160P63 180°

EAN 4031582398168



BETTER MOBILITY. BETTER LIFE.

## Structure & Mounting

