

GALEA

5077PJH100P30-12

EAN 4031582379006

Swivel castor with total lock, tail end of castor, housing made of Polyamide, double ball bearing swivel head, bolt hole. Wheel centre made of Polypropylene, Tread: TENTEprene (thermoplastic rubber), grey non-marking, with threadguards, plain bearing
Hint: These castors are also with grey locking lever available.



BETTER MOBILITY. BETTER LIFE.



Picture may differ from original product

Technical Data

Wheel diameter	100 mm
Wheel width	30 mm
Castor width	66 mm
Centre hole	12 mm
Dome-Ø	59 mm
Offset	40 mm
Swivel Interference	256 mm
Overall height	139 mm
Temperature	-20 / +60 °C
Standard	EN 12530
Weight	0.456 kg
Swivel Radius	128 mm
Hardness of tread	Shore A 87
Load capacity	100 kg
Load capacity (static)	200 kg

Advantages at a glance

Roll performance	● ● ● ○ ○
Movement noise	● ● ● ○ ○
Attrition	● ● ● ● ○
Corrosion resistance	● ● ● ○ ○

Dimensions

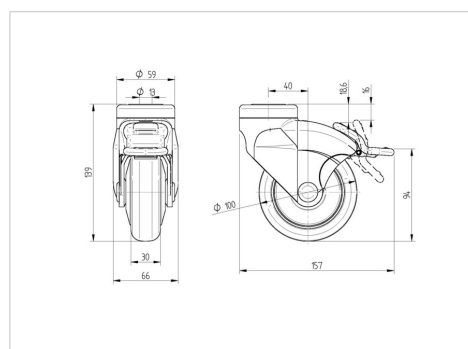

Structure & Mounting

