

ICS

5327PJP100P50

EAN

4031582367423



Image may differ from the original product

PERFORMANCE

Roll performance	● ● ● ○ ○
Movement noise	● ● ● ● ●
Attrition	● ● ● ○ ○
Corrosion resistance	● ● ● ● ●

CORE ATTRIBUTES

Product name	ICS
Product type	Swivel castor with total lock
Standard	EN12530 - Devices Castors
Load capacity at 3 km/h	100 kg
Load capacity Static	200 kg
Temperature range (Minimum)	-10 °C
Temperature range (Maximum)	40 °C
Overall height	141 mm
Overall weight	0.591 kg

WHEEL

Body material	Polypropylene
Tread material	Thermoplastic rubber
Bearing	Precision ball bearing
Threadguards	Integrated threadguard
Diameter	100 mm
Tread width	32 mm
Hardness of tread (A)	87 Shore A

HOUSING

Material	Polyamide
Fork shape	Slim
Swivel bearing	Stem, swiveling
Offset	37 mm
Swivel interference	240 mm

FITTING

Fitting type	Rectangular plate
Plate length	77 mm
Plate width	67 mm
Plate hole length (Minimum)	56 mm
Plate hole length (Maximum)	61.5 mm
Plate hole width (Minimum)	46.5 mm
Plate hole width (Maximum)	51.5 mm
Plate hole diameter	8.5 mm



IF
Design
Award

ICS

5327PJP100P50

EAN

4031582367423

TECHNICAL DRAWINGS

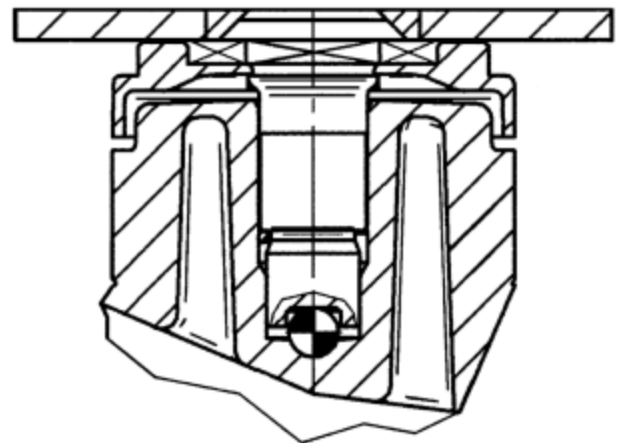
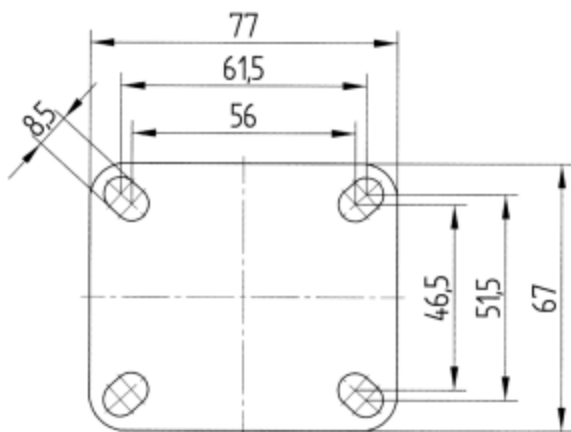
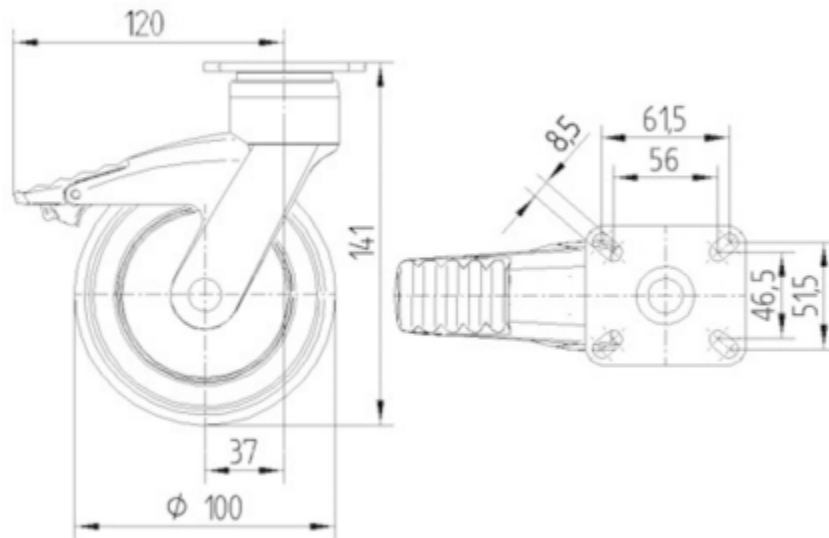

IF
Design
Award