

## 5327PJP100S70

EAN 4031582367485

Swivel caster with total lock, trailing end of caster, housing and wheels made from high grade synthetic materials, with integrated threadguards, all metal parts are bright zinc plated, yellow thick layer passivated, threaded stem with hex neck. Wheel center made of Polypropylene, Tread: TENTEprene (thermoplastic rubber), grey non-marking, precision ball bearing, with threadguards. Please read the assembly instructions in the service area of the TENTE website.

Hint: These casters are available with grey locking lever.



BETTER MOBILITY. BETTER LIFE.



Picture may differ from original product

### Technical Data

Wheel diameter	100 mm
Wheel width	32 mm
Threaded stem	M 10 x 17 mm
Offset	37 mm
Swivel Interference	240 mm
Overall height	137 mm
Temperature	- 10 / + 40 °C
Standard	EN 12530
Weight	0.463 kg
Hardness of tread	Shore A 87
Load capacity (dynamic)	100 kg
Load capacity (static)	200 kg

### Advantages at a glance

Roll performance	● ● ● ● ○
Movement noise	● ● ● ● ○
Attrition	● ● ● ● ○
Corrosion resistance	● ● ● ● ○

### Dimensions

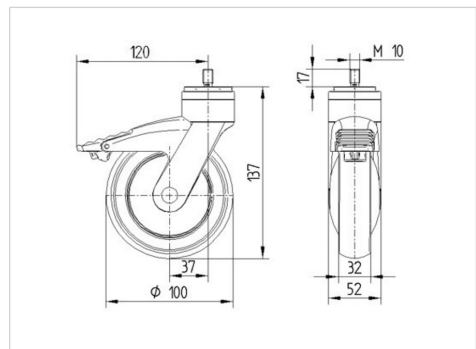

### Structure & Mounting

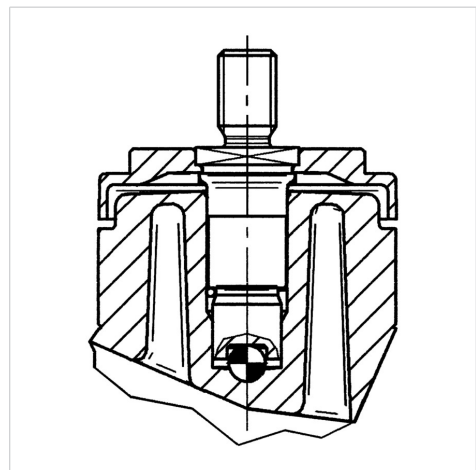

5327PJP100S70

EAN 4031582367485



BETTER MOBILITY. BETTER LIFE.

**Structure & Mounting**

---

