

5327PJP125P50

EAN 4031582367430

Swivel caster with total lock, trailing end of caster, housing and wheels made from high grade synthetic materials, with integrated threadguards, all metal parts are bright zinc plated, yellow thick layer passivated, plate fitting. Wheel center made of Polypropylene, Tread: TENTEprene (thermoplastic rubber), grey non-marking, precision ball bearing, with threadguards

Hint: These casters are available with grey locking lever.



BETTER MOBILITY. BETTER LIFE.



Picture may differ from original product

Technical Data

Wheel diameter	125 mm
Wheel width	32 mm
Plate size	77 x 67 mm
Plate hole centers	61,5/56 x 51,5/46,5 mm
Plate hole	8,5 mm
Offset	38 mm
Swivel Interference	259 mm
Overall height	166 mm
Temperature	- 10 / + 40 °C
Standard	EN 12530
Weight	0.699 kg
Hardness of tread	Shore A 87
Load capacity (dynamic)	100 kg
Load capacity (static)	200 kg

Advantages at a glance

Roll performance	● ● ● ○ ○
Movement noise	● ● ● ○ ○
Attrition	● ● ● ○ ○
Corrosion resistance	● ● ● ● ○

Dimensions

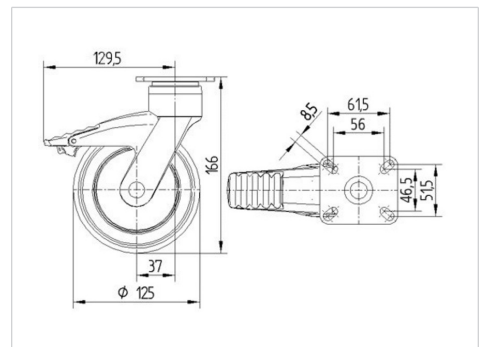

Structure & Mounting

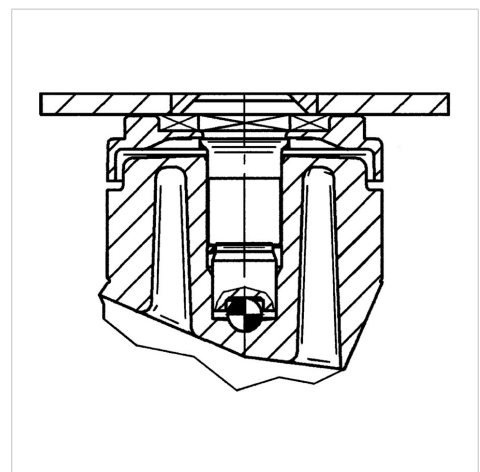



BETTER MOBILITY. BETTER LIFE.

5327PJP125P50

EAN 4031582367430

Structure & Mounting

