

## 5327PJX125P51 INOX

EAN 4031582367447

Swivel castor with total lock, tail end of castor, housing and wheels made from high grade synthetic materials, with integrated threadguards, all metal parts are made of Stainless Steel, plate fitting. Wheel centre made of Polypropylene, Tread: TENTEprene (thermoplastic rubber), grey non-marking, with threadguards, precision ball bearing, sealed  
Hint: These castors are also with grey locking lever available.



BETTER MOBILITY. BETTER LIFE.



Picture may differ from original product

### Technical Data

Wheel diameter	125 mm
Wheel width	32 mm
Size of Plate	95 x 70 mm
Plate hole centres	75 x 50 mm
Plate hole	11 mm
Offset	38 mm
Swivel Interference	259 mm
Overall height	166 mm
Temperature	- 10 / + 40 °C
Standard	EN 12530
Weight	0.719 kg
Hardness of tread	Shore A 87
Load capacity	100 kg
Load capacity (static)	200 kg

### Advantages at a glance

Roll performance	● ● ● ○ ○
Movement noise	● ● ● ● ○
Attrition	● ● ● ○ ○
Corrosion resistance	● ● ● ● ●

### Dimensions

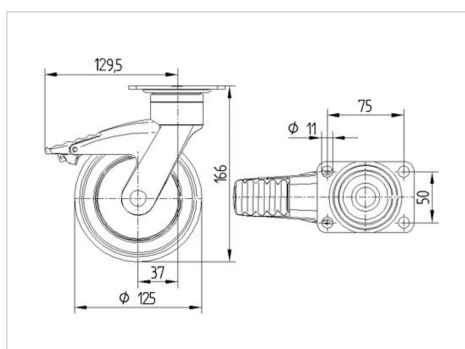

### Structure & Mounting

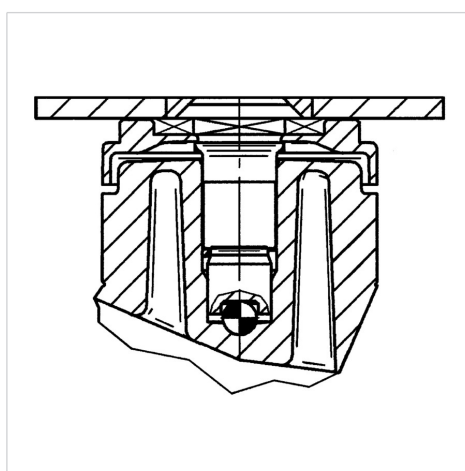



BETTER MOBILITY. BETTER LIFE.

## 5327PJX125P51 INOX

EAN 4031582367447

### Structure & Mounting

