

5327UAP100R05-18x62

EAN 4031582367539

Swivel castor with total lock, tail end of castor, housing and wheels made from high grade synthetic materials, with integrated threadguards, all metal parts are bright zinc plated, yellow thick layer passivated, solid plug fitting. Wheel centre made of Polyamide, Tread: Polyurethane, precision ball bearing

Hint: These castors are also with grey locking lever available.



BETTER MOBILITY. BETTER LIFE.



Picture may differ from original product

Technical Data

Wheel diameter	100 mm
Wheel width	32 mm
Bolt-Ø	18 mm
Bolt length	62 mm
Offset	37 mm
Swivel Interference	240 mm
Overall height	137 mm
Temperature	- 10 / + 40 °C
Standard	EN 12530
Weight	0.61 kg
Hardness of tread	Shore D 42
Load capacity	100 kg
Load capacity (static)	200 kg

Advantages at a glance

Roll performance	● ● ● ○ ○
Movement noise	● ● ● ● ○
Attrition	● ● ● ● ○
Corrosion resistance	● ● ● ● ○

Dimensions

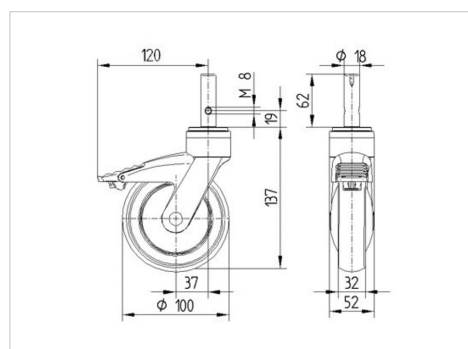

Structure & Mounting

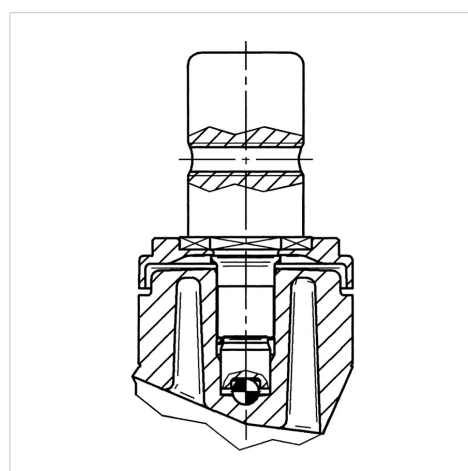

5327UAP100R05-18x62

EAN 4031582367539



BETTER MOBILITY. BETTER LIFE.

Structure & Mounting

