



BETTER MOBILITY. BETTER LIFE.

5327UAX125R05-18x62 INOX

EAN 4031582367546

Swivel castor with total lock, tail end of castor, housing and wheels made from high grade synthetic materials, with integrated threadguards, solid plug fitting. Wheel centre made of Polyamide, Tread: Polyurethane, with threadguards, precision ball bearing, sealed

Hint: These castors are also with grey locking lever available.all metal parts are made of Stainless Steel.



Picture may differ from original product

Technical Data

Wheel diameter	125 mm
Wheel width	32 mm
Bolt-Ø	18 mm
Bolt length	62 mm
Offset	38 mm
Swivel Interference	259 mm
Overall height	162 mm
Temperature	- 10 / + 40 °C
Standard	EN 12530
Weight	0.774 kg
Hardness of tread	Shore D 42
Load capacity	100 kg
Load capacity (static)	200 kg

Structure & Mounting

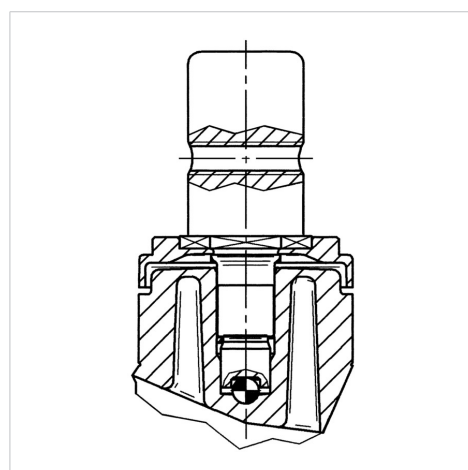

Advantages at a glance

Roll performance	● ● ● ○ ○
Movement noise	● ● ● ● ○
Attrition	● ● ● ● ○
Corrosion resistance	● ● ● ● ●

5327UAX125R05-18x62 INOX

EAN 4031582367546



BETTER MOBILITY. BETTER LIFE.

Structure & Mounting

