

5327XSX125P51 INOX

EAN 4031582367706

Swivel caster with total lock, trailing end of caster, housing and wheels made from high grade synthetic materials, with integrated threadguards, all metal parts are made of Stainless Steel, plate fitting. Wheel center made of Polyamide, electric conductive, Tread made of injected Polyurethane, with threadguards, precision ball bearing, sealed. Hint: These casters are available with grey locking lever.



BETTER MOBILITY. BETTER LIFE.



Picture may differ from original product

Technical Data

Wheel diameter	125 mm
Wheel width	32 mm
Plate size	95 x 70 mm
Plate hole centers	75 x 50 mm
Plate hole	11 mm
Offset	38 mm
Swivel Interference	259 mm
Overall height	166 mm
Temperature	- 10 / + 40 °C
Standard	EN 12530
Weight	0.789 kg
Hardness of tread	Shore D 40
Load capacity (dynamic)	100 kg
Load capacity (static)	200 kg

Advantages at a glance

Roll performance	● ● ● ○ ○
Movement noise	● ● ● ○ ○
Attrition	● ● ● ○ ○
Corrosion resistance	● ● ● ● ○

Dimensions

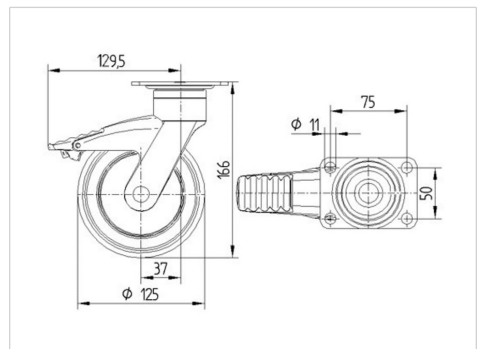

Structure & Mounting

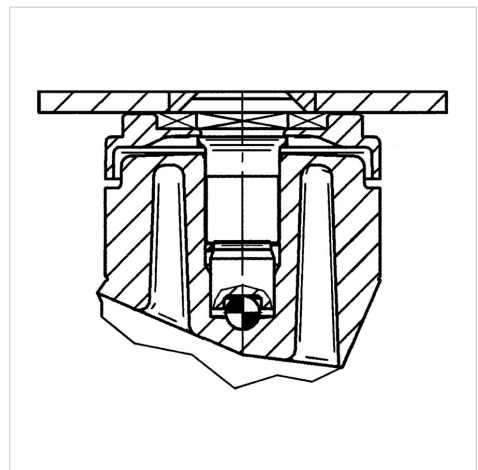



BETTER MOBILITY. BETTER LIFE.

5327XSX125P51 INOX

EAN 4031582367706

Structure & Mounting

