



BETTER MOBILITY. BETTER LIFE.

5327XSX125R05-18x62

EAN 4031582367720

Swivel caster with total lock, trailing end of caster, housing and wheels made from high grade synthetic materials, with integrated threadguards, solid plug fitting. Wheel center made of Polyamide, electric conductive, Tread made of injected Polyurethane, with threadguards, precision ball bearing, sealed.

Hint: These casters are available with grey locking lever.all metal parts are bright zinc plated, yellow thick layer passivated.



Picture may differ from original product

Technical Data

Wheel diameter	125 mm
Wheel width	32 mm
Bolt-Ø	18 mm
Bolt length	62 mm
Offset	38 mm
Swivel Interference	259 mm
Overall height	162 mm
Temperature	- 10 / + 40 °C
Standard	EN 12530
Weight	0.762 kg
Hardness of tread	Shore D 40
Load capacity (dynamic)	100 kg
Load capacity (static)	200 kg

Structure & Mounting

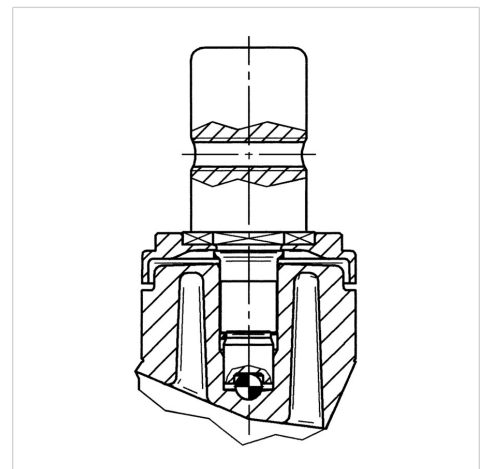

Advantages at a glance

Roll performance	● ● ● ○ ○
Movement noise	● ● ● ● ○
Attrition	● ● ● ○ ○
Corrosion resistance	● ● ● ● ○

5327XSX125R05-18x62

EAN 4031582367720



BETTER MOBILITY. BETTER LIFE.

Structure & Mounting

