



BETTER MOBILITY. BETTER LIFE.

5328PJX125P51 INOX

EAN 4031582310269

Fixed castor, Fork and wheels made from high grade synthetic materials, with integrated threadguards, all metal parts are made of Stainless Steel, plate fitting.

Wheel centre made of Polypropylene, Tread: TENTEprene (thermoplastic rubber), grey non-marking, with threadguards, precision ball bearing, sealed



Picture may differ from original product

Technical Data

Wheel diameter	125 mm
Wheel width	32 mm
Castor width	52 mm
Size of Plate	95 x 70 mm
Plate hole centres	75 x 50 mm
Plate hole	11 mm
Dome-Ø	52 mm
Overall height	166 mm
Temperature	- 10 / + 40 °C
Standard	EN 12530
Weight	0.696 kg
Hardness of tread	Shore A 87
Load capacity	100 kg
Load capacity (static)	200 kg

Dimensions

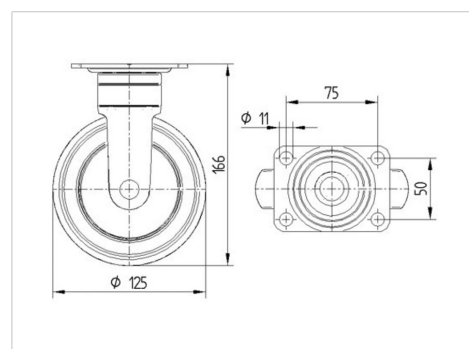

Advantages at a glance

Roll performance	● ● ● ○ ○
Movement noise	● ● ● ● ○
Attrition	● ● ● ○ ○
Corrosion resistance	● ● ● ● ●



BETTER MOBILITY. BETTER LIFE.

5328PJX125P51 INOX

EAN 4031582310269

Structure & Mounting

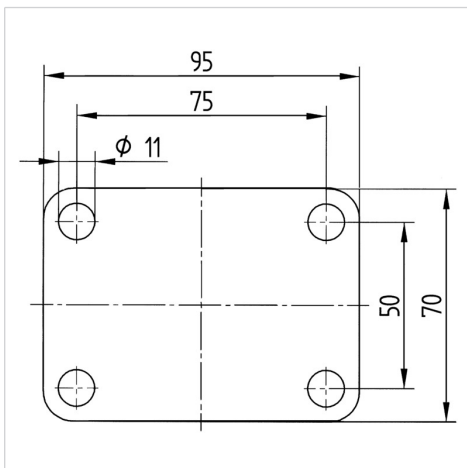

product
design award
winner