



BETTER MOBILITY. BETTER LIFE.

## 5328UAP125P50

EAN 4031582310306

Fixed castor, Fork and wheels made from high grade synthetic materials, with integrated threadguards, all metal parts are bright zinc plated, yellow thick layer passivated, plate fitting.  
 Wheel centre made of Polyamide, Tread: Polyurethane, precision ball bearing



Picture may differ from original product

### Technical Data

Wheel diameter	125 mm
Wheel width	32 mm
Size of Plate	77 x 67 mm
Plate hole centres	61,5/56 x 51,5/46,5 mm
Plate hole	8,5 mm
Overall height	166 mm
Temperature	- 10 / + 40 °C
Standard	EN 12530
Weight	0.672 kg
Hardness of tread	Shore D 42
Load capacity	100 kg
Load capacity (static)	200 kg

### Dimensions

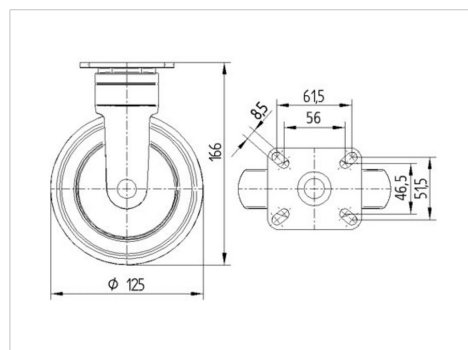

### Advantages at a glance

Roll performance	● ● ● ○ ○
Movement noise	● ● ● ● ○
Attrition	● ● ● ● ○
Corrosion resistance	● ● ● ● ○



BETTER MOBILITY. BETTER LIFE.

## 5328UAP125P50

EAN 4031582310306

### Structure & Mounting

