

ALPHA

8477UFC100P62

EAN 4031582422535

Swivel castor with total lock, tail end of castor, Housing made of Stainless Steel, double ball bearing swivel head, wheel axle with nut, plate fitting. Wheel centre made of Polyamide, Tread: elastic-tyre, non-marking, with small threadguards, INOX precision ball bearing



BETTER MOBILITY. BETTER LIFE.



Picture may differ from original product

Technical Data

Wheel diameter	100 mm
Wheel width	34 mm
Size of Plate	105 x 80 mm
Plate hole centres	80/77 x 60 mm
Plate hole	9 mm
Offset	41 mm
Swivel Interference	242 mm
Overall height	128 mm
Temperature	- 20 / + 80 °C
Standard	EN 12532
Weight	1.014 kg
Hardness of tread	Shore A 64
Load capacity	160 kg
Load capacity (static)	320 kg

Advantages at a glance

Roll performance	● ● ● ○ ○
Movement noise	● ● ● ● ●
Attrition	● ● ● ○ ○
Corrosion resistance	● ● ● ● ●

Dimensions



Structure & Mounting

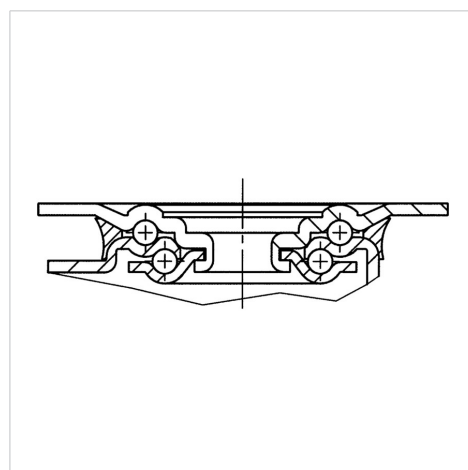

ALPHA

8477UFC100P62

EAN 4031582422535



BETTER MOBILITY. BETTER LIFE.

Structure & Mounting

