

ALPHA

8477UFX160P63

EAN 4031582313048

Swivel castor with total lock, tail end of castor, Housing made of Stainless Steel, double ball bearing swivel head, wheel axle with nut, plate fitting. Wheel centre made of Polyamide, Tread: elastic-tyre, non-marking, with small threadguards, precision ball bearing, sealed



BETTER MOBILITY. BETTER LIFE.



Picture may differ from original product

Technical Data

Wheel diameter	160 mm
Wheel width	46 mm
Castor width	96 mm
Size of Plate	137 x 105 mm
Plate hole centres	105 x 80/75 mm
Plate hole	11 mm
Dome-Ø	96 mm
Offset	60 mm
Swivel Interference	334 mm
Overall height	200 mm
Temperature	- 20 / + 80 °C
Standard	EN 12532
Weight	2.558 kg
Swivel Radius	167 mm
Hardness of tread	Shore A 63
Load capacity	250 kg
Load capacity (static)	500 kg

Advantages at a glance

Roll performance	● ● ● ○ ○
Movement noise	● ● ● ● ●
Attrition	● ● ● ○ ○
Corrosion resistance	● ● ● ● ●

Dimensions

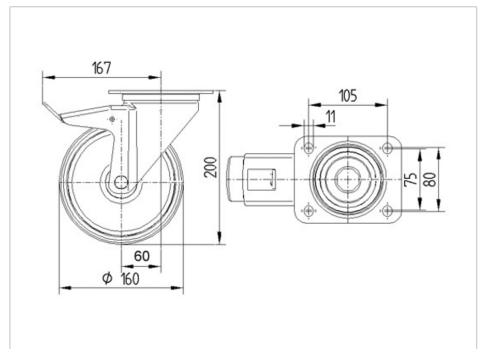

Structure & Mounting

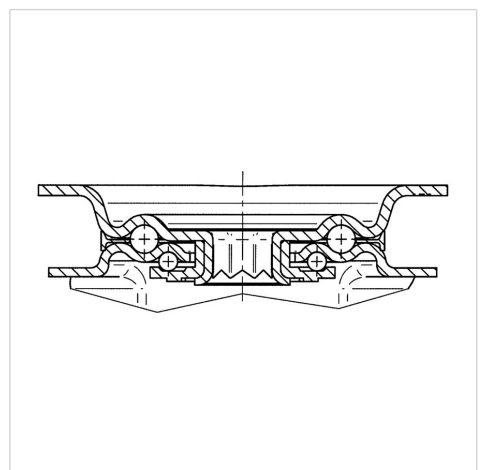

ALPHA

8477UFX160P63

EAN 4031582313048



BETTER MOBILITY. BETTER LIFE.

Structure & Mounting

