

ZETA

8671TOO125P63

EAN 4031582313574

Swivel castor with directional lock, housing made of Stainless Steel, double ball bearing swivel head, protected, reinforced and heat-treated ball covers, riveted king pin, wheel axle with nut, plate fitting. Wheel centre made of Polyamide, heavy duty, plain bearing



BETTER MOBILITY. BETTER LIFE.



Picture may differ from original product

Technical Data

Wheel diameter	125 mm
Wheel width	50 mm
Castor width	96 mm
Size of Plate	137 x 105,0 mm
Plate hole centres	105 x 80/74 mm
Plate hole	11 mm
Dome-Ø	96 mm
Offset	55 mm
Swivel Interference	240 mm
Overall height	164 mm
Temperature	- 30 / + 80 °C
Standard	EN 12533
Weight	2.742 kg
Swivel Radius	120 mm
Hardness of tread	Shore D 75
Load capacity	700 kg
Load capacity (static)	1400 kg

Advantages at a glance

Roll performance	● ● ● ● ●
Movement noise	● ○ ○ ○ ○
Attrition	● ● ● ● ●
Corrosion resistance	● ● ● ● ●

Dimensions

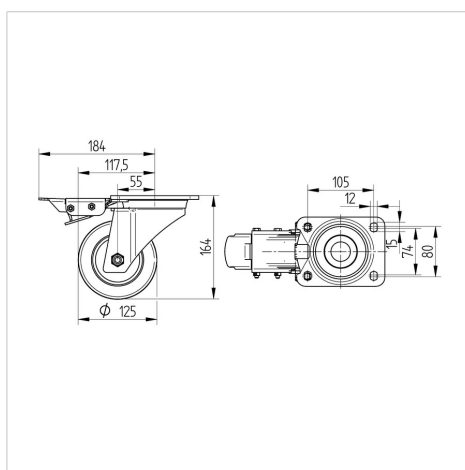

Structure & Mounting

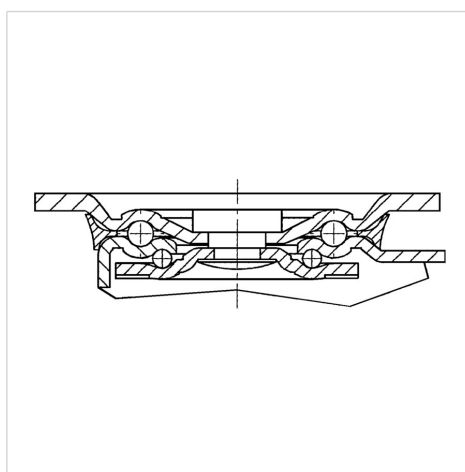

ZETA

8671TOO125P63

EAN 4031582313574



BETTER MOBILITY. BETTER LIFE.

Structure & Mounting

