

# KAPPA

9650FTP200P64

EAN 4031582314212

Swivel castor, housing and plate steel-welded, bright zinc plated, blue passivated, sealed swivel bearing with dual purpose bearing and tapered roller bearing, threaded king pin and locking nut secured, grease nipple, wheel axle with nut, plate fitting. Wheel centre made of cast iron, Tread: Polyurethane, casted, precision ball bearing



BETTER MOBILITY. BETTER LIFE.



Picture may differ from original product

## Technical Data

Wheel diameter	200 mm
Wheel width	80 mm
Castor width	140 mm
Size of Plate	175 x 140 mm
Plate hole centres	140 x 105 mm
Plate hole	15 mm
Dome-Ø	140 mm
Offset	65 mm
Swivel Interference	340 mm
Overall height	255 mm
Temperature	- 10 / + 60 °C
Standard	EN 12533
Weight	13.052 kg
Swivel Radius	170 mm
Hardness of tread	Shore D 42
Load capacity	1400 kg
Load capacity (static)	2800 kg

## Advantages at a glance

Roll performance	● ● ● ● ○
Movement noise	● ● ● ○ ○
Attrition	● ● ● ● ○
Corrosion resistance	● ● ● ○ ○

## Dimensions

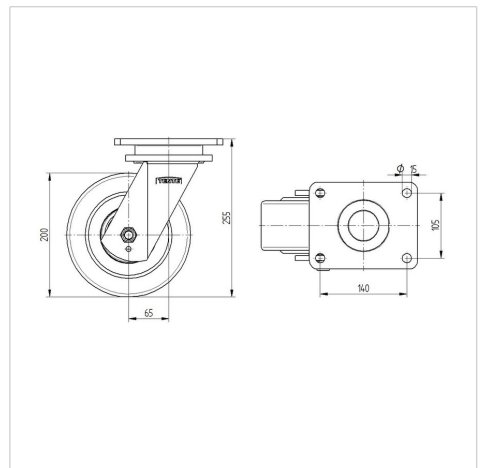

## Structure & Mounting

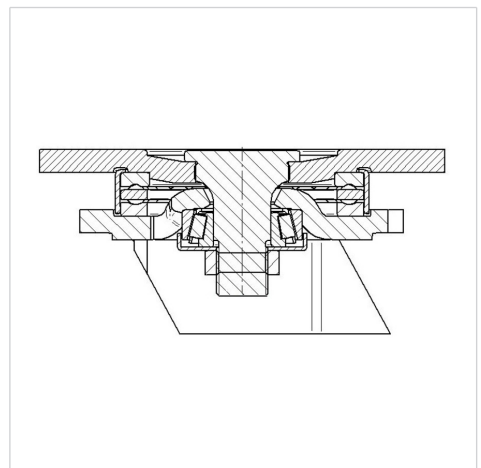

# KAPPA

9650FTP200P64

EAN 4031582314212



BETTER MOBILITY. BETTER LIFE.

## Structure & Mounting

---

