

# KAPPA

9650TOO150P63

EAN 4031582314342

Swivel castor, housing and plate steel-welded, bright zinc plated, blue passivated, sealed swivel bearing with dual purpose bearing and tapered roller bearing, threaded king pin and locking nut secured, grease nipple, wheel axle with nut, plate fitting. Wheel centre made of Polyamide, heavy duty, plain bearing



BETTER MOBILITY. BETTER LIFE.



Picture may differ from original product

## Technical Data

Wheel diameter	150 mm
Wheel width	50 mm
Size of Plate	135 x 110 mm
Plate hole centres	105 x 80/75 mm
Plate hole	11 mm
Offset	58 mm
Swivel Interference	266 mm
Overall height	200 mm
Temperature	- 40 / + 80 °C
Standard	EN 12533
Weight	3.856 kg
Swivel Radius	133 mm
Hardness of tread	Shore D 75
Load capacity	800 kg
Load capacity (static)	1600 kg

## Advantages at a glance

Roll performance	● ● ● ● ●
Movement noise	● ○ ○ ○ ○
Attrition	● ● ● ● ●
Corrosion resistance	● ● ● ○ ○

## Dimensions

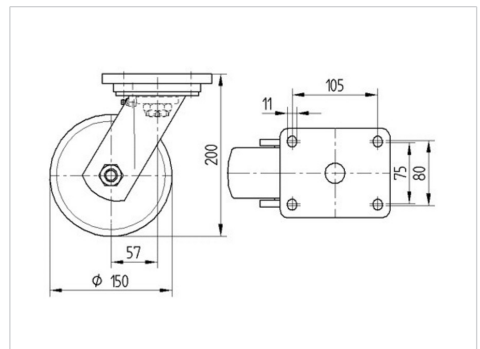

## Structure & Mounting

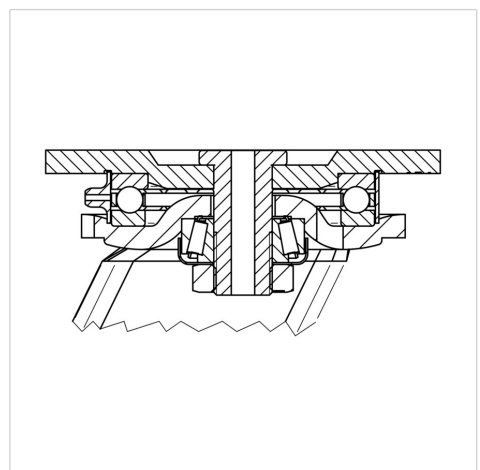

# KAPPA

9650TOO150P63

EAN 4031582314342



BETTER MOBILITY. BETTER LIFE.

## Structure & Mounting

