

KAPPA

9651FTP300P64

EAN 4031582314557

Swivel castor with directional lock, housing and plate steel-welded, bright zinc plated, blue passivated, sealed swivel bearing with dual purpose bearing and tapered roller bearing, threaded king pin and locking nut secured, grease nipple, wheel axle with nut, plate fitting. Wheel centre made of cast iron, Tread: Polyurethane, casted, precision ball bearing



BETTER MOBILITY. BETTER LIFE.



Picture may differ from original product

Technical Data

Wheel diameter	300 mm
Wheel width	80 mm
Castor width	140 mm
Size of Plate	175 x 140 mm
Plate hole centres	140 x 105 mm
Plate hole	15 mm
Dome-Ø	140 mm
Offset	76 mm
Swivel Interference	460 mm
Overall height	355 mm
Temperature	- 10 / + 60 °C
Standard	EN 12533
Weight	21.654 kg
Swivel Radius	230 mm
Hardness of tread	Shore D 42
Load capacity	2000 kg
Load capacity (static)	4000 kg

Advantages at a glance

Roll performance	● ● ● ● ○
Movement noise	● ● ● ○ ○
Attrition	● ● ● ● ○
Corrosion resistance	● ● ● ○ ○

Dimensions

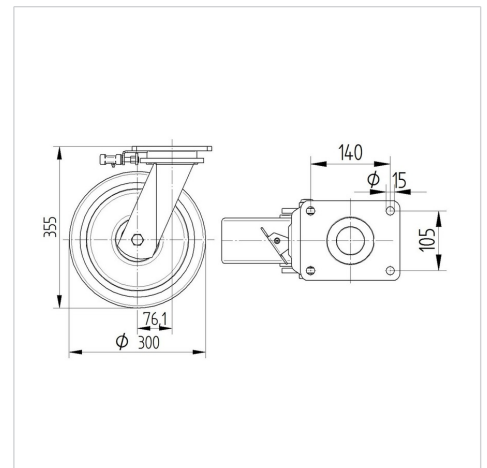

Structure & Mounting

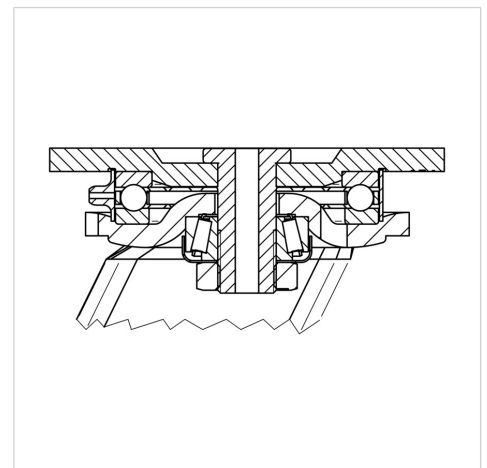

KAPPA

9651FTP300P64

EAN 4031582314557



BETTER MOBILITY. BETTER LIFE.

Structure & Mounting

