

# KAPPA

## 9652FTP200P63 WT60

EAN 4031582314748

Swivel caster with total lock, leading end of caster, housing and plate steel-welded, bright zinc plated, blue passivated, sealed swivel bearing with dual purpose bearing and tapered roller bearing, threaded king pin and locking nut secured, grease nipple, wheel axle with nut, plate fitting. Wheel center made of cast iron, Tread: Polyurethane, casted, precision ball bearing



BETTER MOBILITY. BETTER LIFE.



Picture may differ from original product

### Technical Data

Wheel diameter	200 mm
Wheel width	60 mm
Caster width	116 mm
Plate size	135 x 110 mm
Plate hole centers	105 x 80/75 mm
Plate hole	11 mm
Dome-Ø	111 mm
Offset	59 mm
Swivel Interference	320 mm
Overall height	245 mm
Temperature	- 10 / + 60 °C
Standard	EN 12533
Weight	9.057 kg
Swivel Radius	160 mm
Hardness of tread	Shore D 42
Load capacity (dynamic)	1200 kg
Load capacity (static)	2400 kg

### Advantages at a glance

Roll performance	● ● ● ● ○
Movement noise	● ● ● ○ ○
Attrition	● ● ● ● ○
Corrosion resistance	● ● ● ○ ○

### Dimensions

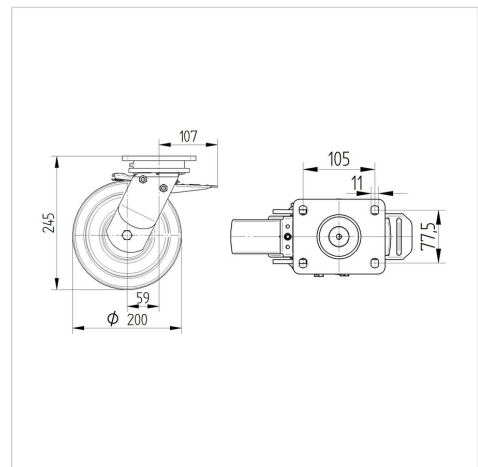

### Structure & Mounting

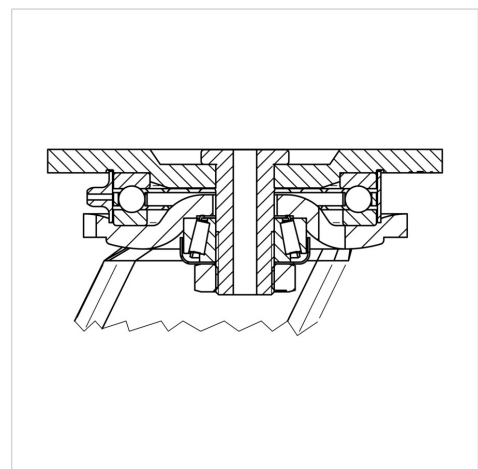

# KAPPA

9652FTP200P63 WT60

EAN 4031582314748



BETTER MOBILITY. BETTER LIFE.

## Structure & Mounting

