

KAPPA

9652FTP250P63

EAN 4031582314779

Swivel castor with total lock, head end of castor, housing and plate steel-welded, bright zinc plated, blue passivated, sealed swivel bearing with dual purpose bearing and tapered roller bearing, threaded king pin and locking nut secured, grease nipple, wheel axle with nut, plate fitting. Wheel centre made of cast iron, Tread: Polyurethane, casted, precision ball bearing



BETTER MOBILITY. BETTER LIFE.



Picture may differ from original product

Technical Data

Wheel diameter	250 mm
Wheel width	50 mm
Castor width	116 mm
Size of Plate	135 x 110 mm
Plate hole centres	105 x 80/75 mm
Plate hole	11 mm
Dome-Ø	111 mm
Offset	61 mm
Swivel Interference	375 mm
Overall height	305 mm
Temperature	- 10 / + 60 °C
Standard	EN 12533
Weight	10.271 kg
Swivel Radius	187.5 mm
Hardness of tread	Shore D 42
Load capacity	1200 kg
Load capacity (static)	2400 kg

Advantages at a glance

Roll performance	● ● ● ● ○
Movement noise	● ● ● ○ ○
Attrition	● ● ● ● ○
Corrosion resistance	● ● ● ○ ○

Dimensions

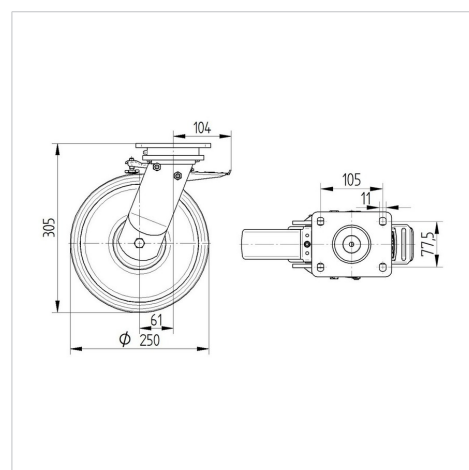

Structure & Mounting

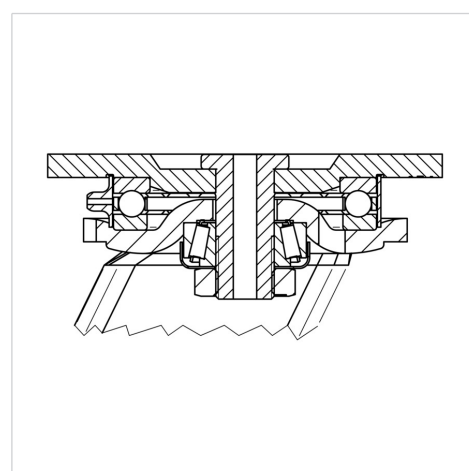

KAPPA

9652FTP250P63

EAN 4031582314779



BETTER MOBILITY. BETTER LIFE.

Structure & Mounting

