

KAPPA

9652TOO160P63

EAN 4031582314892

Swivel caster with total lock, leading end of caster, housing and plate steel-welded, bright zinc plated, blue passivated, sealed swivel bearing with dual purpose bearing and tapered roller bearing, threaded king pin and locking nut secured, grease nipple, wheel axle with nut, plate fitting. Wheel center made of Polyamide, heavy duty, plain bearing



BETTER MOBILITY. BETTER LIFE.



Picture may differ from original product

Technical Data

Wheel diameter	160 mm
Wheel width	50 mm
Plate size	135 x 110 mm
Plate hole centers	105 x 80/75 mm
Plate hole	11 mm
Offset	58 mm
Swivel Interference	276 mm
Overall height	205 mm
Temperature	- 40 / + 80 °C
Standard	EN 12533
Weight	4.399 kg
Hardness of tread	Shore D 75
Load capacity (dynamic)	850 kg
Load capacity (static)	1700 kg

Dimensions

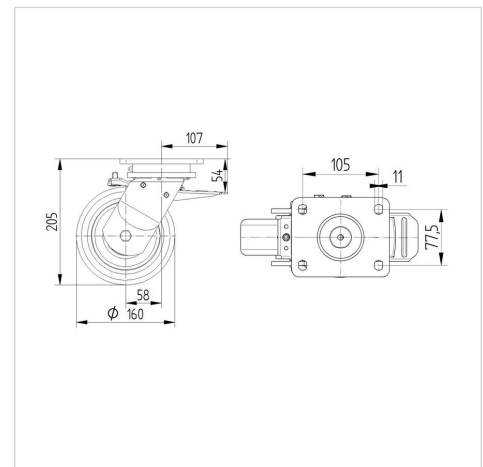

Structure & Mounting

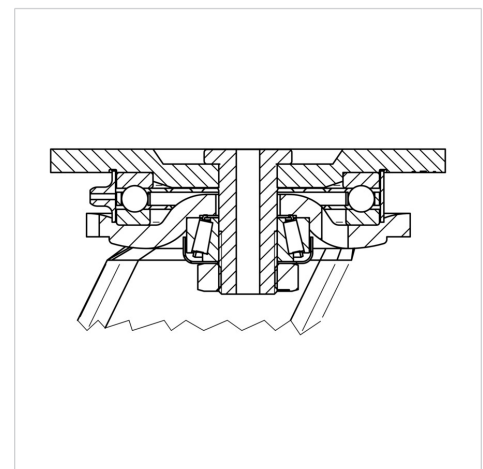

Advantages at a glance

Roll performance	● ● ● ● ●
Movement noise	● ○ ○ ○ ○
Attrition	● ● ● ● ●
Corrosion resistance	● ● ● ○ ○

KAPPA

9652TOO160P63

EAN 4031582314892



BETTER MOBILITY. BETTER LIFE.

Structure & Mounting

