

KAPPA

9681ETP080P63

EAN 4031582315356

Swivel caster with directional lock, housing and plate steel-welded, bright zinc plated, blue passivated, sealed single swivel double ball bearing, threaded king pin and locking nut secured, grease nipple, wheel axle with nut, plate fitting. Wheel center made of steel, Tread: Polyurethane, casted, precision ball bearing.



BETTER MOBILITY. BETTER LIFE.



Picture may differ from original product

Technical Data

Wheel diameter	80 mm
Wheel width	60 mm
Caster width	110 mm
Plate size	135 x 110 mm
Plate hole centers	105 x 80/75 mm
Plate hole	11 mm
Dome-Ø	111 mm
Offset	41 mm
Swivel Interference	178 mm
Overall height	135 mm
Temperature	- 10 / + 60 °C
Standard	EN 12533
Weight	4.274 kg
Swivel Radius	89 mm
Hardness of tread	Shore D 42
Load capacity (dynamic)	500 kg
Load capacity (static)	1000 kg

Advantages at a glance

Roll performance	● ● ● ● ○
Movement noise	● ● ● ○ ○
Attrition	● ● ● ● ○
Corrosion resistance	● ● ● ○ ○

Dimensions

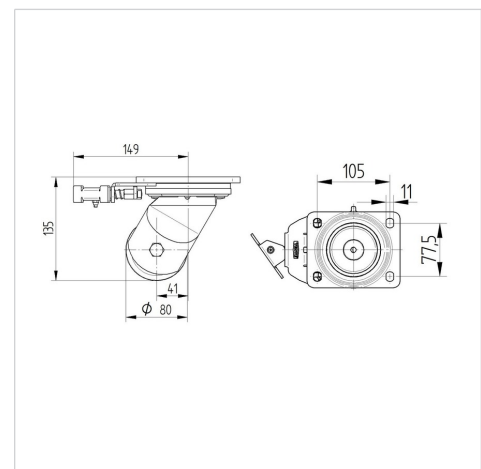

Structure & Mounting

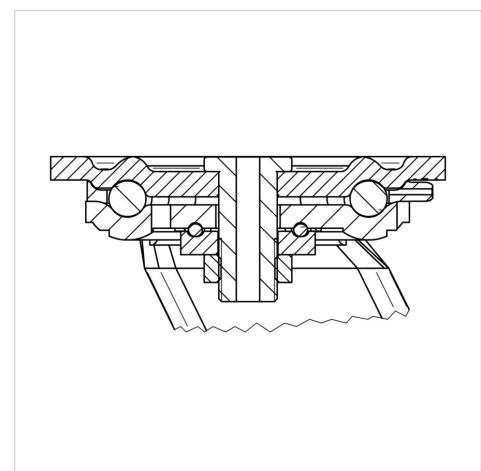

KAPPA

9681ETP080P63

EAN 4031582315356



BETTER MOBILITY. BETTER LIFE.

Structure & Mounting

