

# KAPPA

9681IEP160P63

EAN 4031582315530

Swivel castor with directional lock, housing and plate steel-welded, bright zinc plated, blue passivated, sealed single swivel double ball bearing, threaded king pin and locking nut secured, grease nipple, wheel axle with nut, plate fitting. Wheel centre made of Aluminium, Tread: black elastic-tyre, vulcanized, precision ball bearing



BETTER MOBILITY. BETTER LIFE.



Picture may differ from original product

## Technical Data

|                        |                |
|------------------------|----------------|
| Wheel diameter         | 160 mm         |
| Wheel width            | 50 mm          |
| Castor width           | 110 mm         |
| Size of Plate          | 135 x 110 mm   |
| Plate hole centres     | 105 x 80/75 mm |
| Plate hole             | 11 mm          |
| Dome-Ø                 | 111 mm         |
| Offset                 | 58 mm          |
| Swivel Interference    | 280 mm         |
| Overall height         | 205 mm         |
| Temperature            | - 20 / + 85 °C |
| Standard               | EN 12532       |
| Weight                 | 4.458 kg       |
| Swivel Radius          | 140 mm         |
| Hardness of tread      | Shore A 68     |
| Load capacity          | 350 kg         |
| Load capacity (static) | 700 kg         |

## Advantages at a glance

|                      |           |
|----------------------|-----------|
| Roll performance     | ● ● ● ○ ○ |
| Movement noise       | ● ● ● ● ● |
| Attrition            | ● ● ● ○ ○ |
| Corrosion resistance | ● ● ● ○ ○ |

## Dimensions

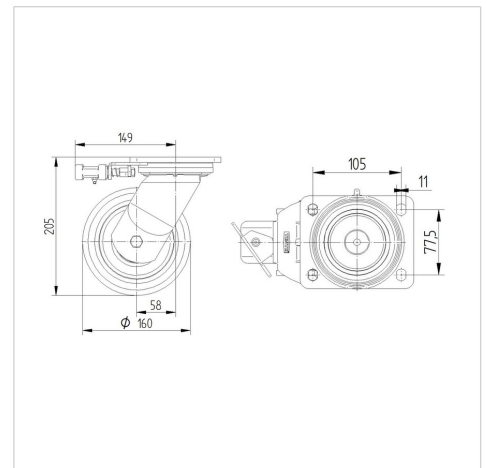

## Structure & Mounting

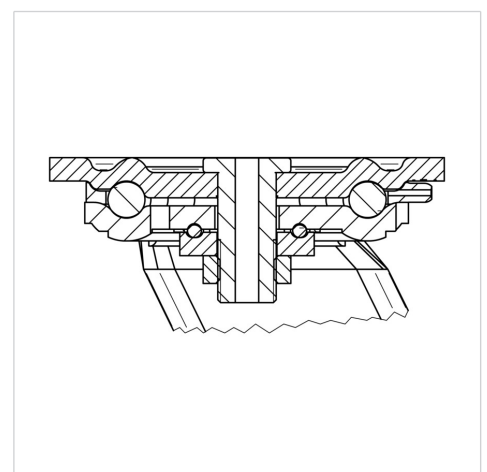

# KAPPA

9681IEP160P63

EAN 4031582315530



BETTER MOBILITY. BETTER LIFE.

## Structure & Mounting

