

# KAPPA

## 9681ITP125P63 Flat

EAN 4031582315578

Swivel castor with directional lock, housing and plate steel-welded, bright zinc plated, blue passivated, sealed single swivel double ball bearing, threaded king pin and locking nut secured, grease nipple, wheel axle with nut, plate fitting. Wheel centre made of Aluminium, Tread: Polyurethane, casted, precision ball bearing



BETTER MOBILITY. BETTER LIFE.



Picture may differ from original product

### Technical Data

Wheel diameter	125 mm
Wheel width	50 mm
Castor width	110 mm
Size of Plate	135 x 110 mm
Plate hole centres	105 x 80/75 mm
Plate hole	11 mm
Dome-Ø	111 mm
Offset	48 mm
Swivel Interference	225 mm
Overall height	170 mm
Temperature	- 10 / + 60 °C
Standard	EN 12532
Weight	3.938 kg
Swivel Radius	112.5 mm
Hardness of tread	Shore D 42
Load capacity	500 kg
Load capacity (static)	1000 kg

### Advantages at a glance

Roll performance	● ● ● ○ ○
Movement noise	● ● ● ○ ○
Attrition	● ● ● ● ○
Corrosion resistance	● ● ● ○ ○

### Dimensions

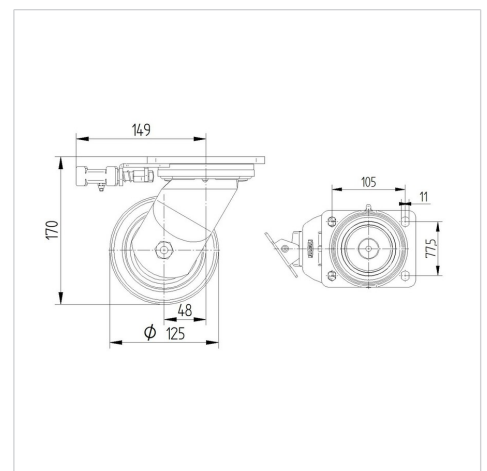

### Structure & Mounting

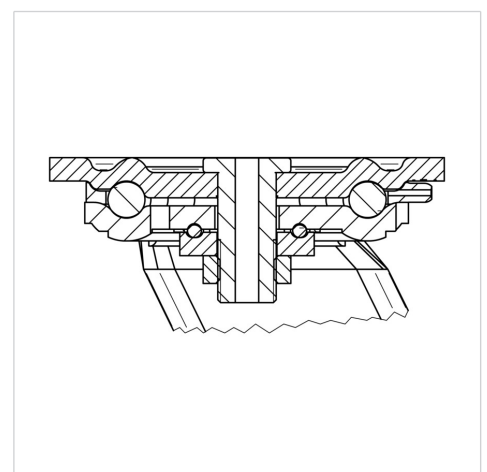

# KAPPA

9681ITP125P63 Flat

EAN 4031582315578



BETTER MOBILITY. BETTER LIFE.

## Structure & Mounting

