

KAPPA

9682IEP200P63

EAN 4031582315912

Swivel caster with total lock, leading end of caster, housing and plate steel-welded, bright zinc plated, blue passivated, sealed single swivel double ball bearing, threaded king pin and locking nut secured, grease nipple, wheel axle with nut, plate fitting. Wheel center made of Aluminum, Tread: black elastic-tire, vulcanized, precision ball bearing



BETTER MOBILITY. BETTER LIFE.



Picture may differ from original product

Technical Data

Wheel diameter	200 mm
Wheel width	50 mm
Caster width	116 mm
Plate size	135 x 110 mm
Plate hole centers	105 x 80/75 mm
Plate hole	11 mm
Dome-Ø	111 mm
Offset	59 mm
Swivel Interference	320 mm
Overall height	245 mm
Temperature	- 20 / + 85 °C
Standard	EN 12532
Weight	5.02 kg
Swivel Radius	160 mm
Hardness of tread	Shore A 68
Load capacity (dynamic)	450 kg
Load capacity (static)	900 kg

Advantages at a glance

Roll performance	● ● ● ○ ○
Movement noise	● ● ● ● ●
Attrition	● ● ● ○ ○
Corrosion resistance	● ● ● ○ ○

Dimensions

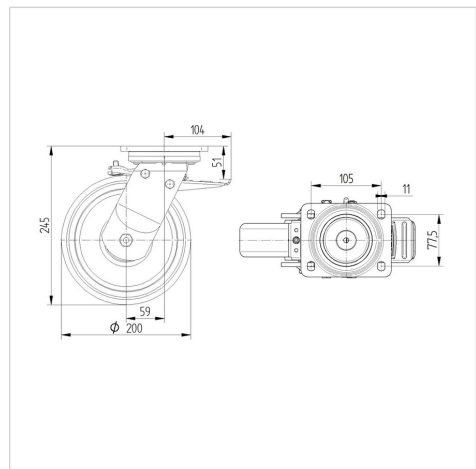

Structure & Mounting

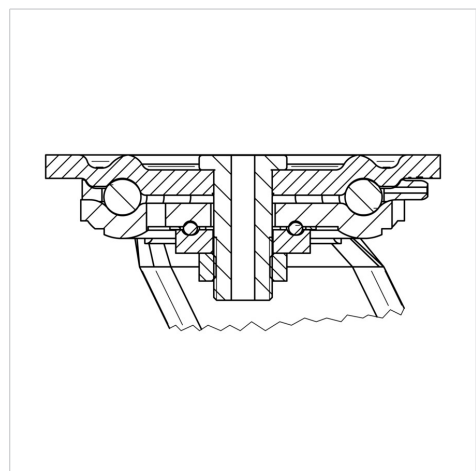

KAPPA

9682IEP200P63

EAN 4031582315912



BETTER MOBILITY. BETTER LIFE.

Structure & Mounting

