

KAPPA

9682ITP250P63 Flat

EAN 4031582315974

Swivel caster with total lock, leading end of caster, housing and plate steel-welded, bright zinc plated, blue passivated, sealed single swivel double ball bearing, threaded king pin and locking nut secured, grease nipple, wheel axle with nut, plate fitting. Wheel center made of Aluminum, Tread: Polyurethane, casted, precision ball bearing



BETTER MOBILITY. BETTER LIFE.



Picture may differ from original product

Technical Data

Wheel diameter	250 mm
Wheel width	55 mm
Caster width	116 mm
Plate size	135 x 110 mm
Plate hole centers	105 x 80/75 mm
Plate hole	11 mm
Dome-Ø	111 mm
Offset	61 mm
Swivel Interference	375 mm
Overall height	305 mm
Temperature	- 10 / + 60 °C
Standard	EN 12532
Weight	5.964 kg
Swivel Radius	187.5 mm
Hardness of tread	Shore D 42
Load capacity (dynamic)	1000 kg
Load capacity (static)	2000 kg

Advantages at a glance

Roll performance	● ● ● ○ ○
Movement noise	● ● ● ○ ○
Attrition	● ● ● ● ○
Corrosion resistance	● ● ● ○ ○

Dimensions

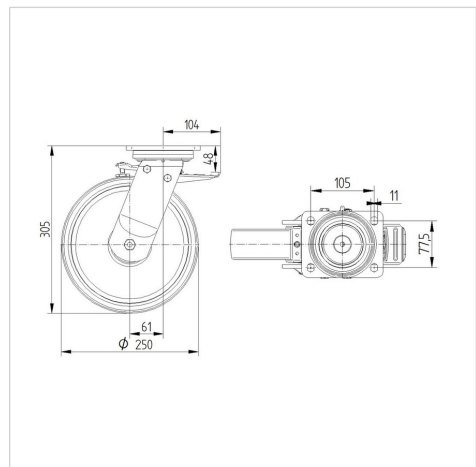

Structure & Mounting

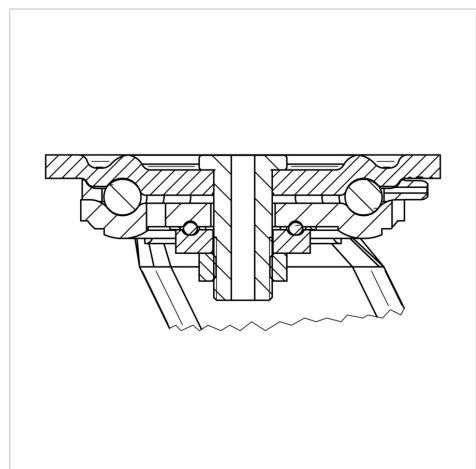

KAPPA

9682ITP250P63 Flat

EAN 4031582315974



BETTER MOBILITY. BETTER LIFE.

Structure & Mounting

