

DELTA TWIN

9940ITP200P63 SH80

EAN 4031582365696

Swivel caster, housing made of heavy pressed steel, bright zinc plated, blue passivated, precision ball bearing swivel head, sealed, wheel axle with nut, plate fitting. Wheel center made of Aluminum, Tread: Polyurethane, casted, precision ball bearing



BETTER MOBILITY. BETTER LIFE.



Picture may differ from original product

Technical Data

Wheel diameter	200 mm
Wheel width	50 mm
Caster width	157 mm
Plate size	137 x 105 mm
Plate hole centers	105 x 80/75 mm
Plate hole	11 mm
Dome- ϕ	136 mm
Offset	55 mm
Swivel Interference	323 mm
Overall height	250 mm
Temperature	- 10 / + 60 °C
Standard	EN 12532
Weight	6.172 kg
Swivel Radius	161.5 mm
Hardness of tread	Shore A 80
Load capacity (dynamic)	750 kg
Load capacity (static)	1500 kg

Dimensions

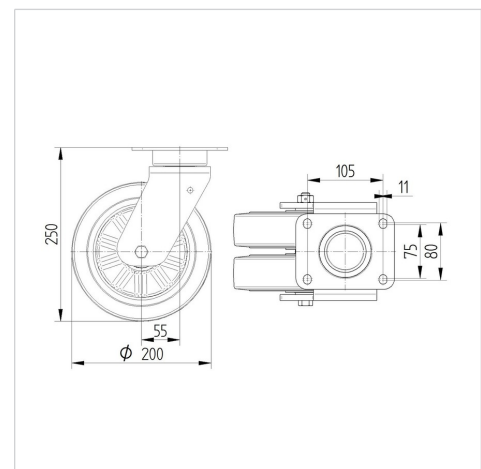

Structure & Mounting

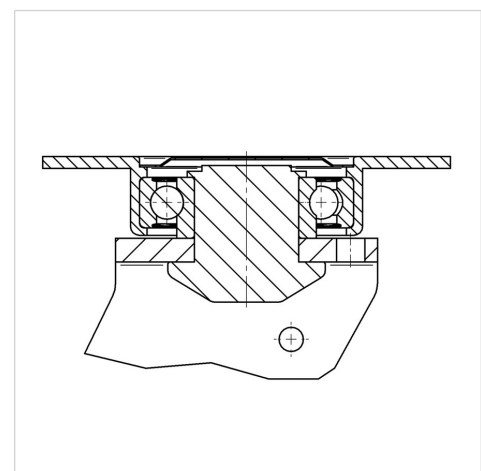

Advantages at a glance

Roll performance	● ● ● ○ ○
Movement noise	● ● ● ○ ○
Attrition	● ● ● ● ○
Corrosion resistance	● ● ● ○ ○

DELTA TWIN

9940ITP200P63 SH80

EAN 4031582365696



BETTER MOBILITY. BETTER LIFE.

Structure & Mounting

