

# OMIKRON TWIN

9950FTP125P65

EAN 4031582316759

Swivel castor, housing and plate steel-welded, zinc plated, blue passivated, sealed swivel bearing with dual purpose bearing and tapered roller bearing, threaded king pin and locking nut secured, grease nipple, wheel axle with nut, plate fitting. Wheel centre made of cast iron, Tread: Polyurethane, casted, precision ball bearing



BETTER MOBILITY. BETTER LIFE.



Picture may differ from original product

## Technical Data

Wheel diameter	125 mm
Wheel width	50 mm
Castor width	189 mm
Size of Plate	200 x 160 mm
Plate hole centres	160 x 120 mm
Plate hole	15 mm
Dome-Ø	160 mm
Offset	50 mm
Swivel Interference	246 mm
Overall height	205 mm
Temperature	- 10 / + 60 °C
Standard	EN 12533
Weight	15.215 kg
Swivel Radius	123 mm
Hardness of tread	Shore D 42
Load capacity	1320 kg
Load capacity (static)	2640 kg

## Advantages at a glance

Roll performance	● ● ● ● ○
Movement noise	● ● ● ○ ○
Attrition	● ● ● ● ○
Corrosion resistance	● ● ● ○ ○

## Dimensions

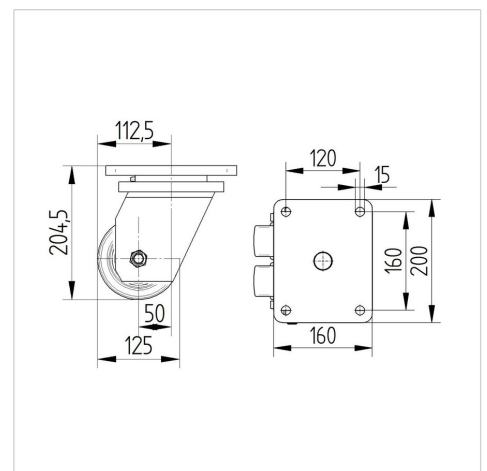

## Structure & Mounting

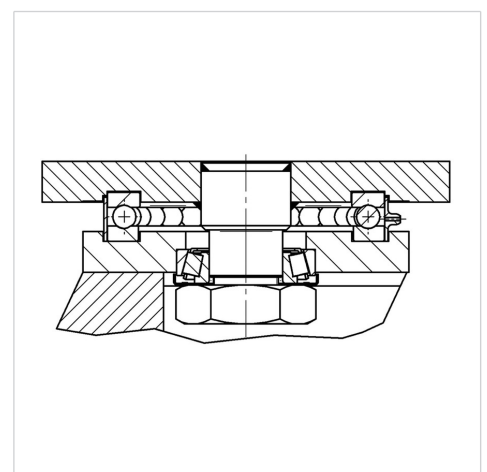

# OMIKRON TWIN

9950FTP125P65

EAN 4031582316759



BETTER MOBILITY. BETTER LIFE.

## Structure & Mounting

