

# OMIKRON TWIN

9950FTP200P68

EAN 4031582316797

Swivel castor, housing and plate steel-welded, zinc plated, blue passivated, sealed swivel bearing with dual purpose bearing and tapered roller bearing, threaded king pin and locking nut secured, grease nipple, wheel axle with nut, plate fitting. Wheel centre made of cast iron, Tread: Polyurethane, casted, precision ball bearing



BETTER MOBILITY. BETTER LIFE.



Picture may differ from original product

## Technical Data

Wheel diameter	200 mm
Wheel width	80 mm
Castor width	272 mm
Size of Plate	270 x 250 mm
Plate hole centres	230 x 210 mm
Plate hole	17 mm
Dome-Ø	250.5 mm
Offset	60 mm
Swivel Interference	374 mm
Overall height	315 mm
Temperature	- 10 / + 60 °C
Standard	EN 12533
Weight	48.586 kg
Swivel Radius	187 mm
Hardness of tread	Shore D 42
Load capacity	3360 kg
Load capacity (static)	6720 kg

## Advantages at a glance

Roll performance	● ● ● ● ○
Movement noise	● ● ● ○ ○
Attrition	● ● ● ● ○
Corrosion resistance	● ● ● ○ ○

## Dimensions

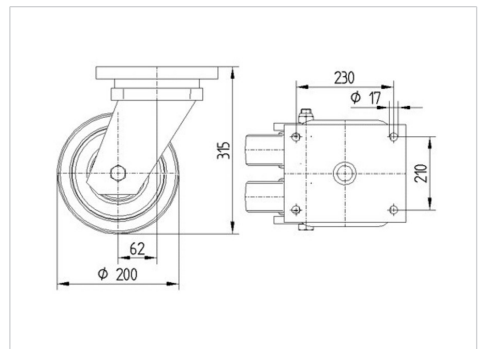

## Structure & Mounting

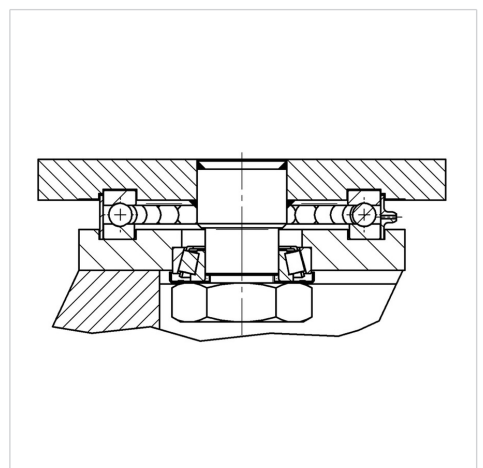

# OMIKRON TWIN

9950FTP200P68

EAN 4031582316797



BETTER MOBILITY. BETTER LIFE.

## Structure & Mounting

