

OMIKRON TWIN

9950FTP300P68

EAN 4031582316827

Swivel castor, housing and plate steel-welded, zinc plated, blue passivated, sealed swivel bearing with dual purpose bearing and tapered roller bearing, threaded king pin and locking nut secured, grease nipple, wheel axle with nut, plate fitting. Wheel centre made of cast iron, Tread: Polyurethane, casted, precision ball bearing



BETTER MOBILITY. BETTER LIFE.



Picture may differ from original product

Technical Data

Wheel diameter	300 mm
Wheel width	80 mm
Castor width	272 mm
Size of Plate	270 x 250 mm
Plate hole centres	230 x 210 mm
Plate hole	17 mm
Dome-Ø	250 mm
Offset	80 mm
Swivel Interference	496 mm
Overall height	415 mm
Temperature	- 10 / + 60 °C
Standard	similar EN12533
Weight	66.898 kg
Swivel Radius	248 mm
Hardness of tread	Shore D 42
Load capacity	4000 kg
Load capacity (static)	8000 kg

Advantages at a glance

Roll performance	● ● ● ● ○
Movement noise	● ● ● ○ ○
Attrition	● ● ● ● ○
Corrosion resistance	● ● ● ○ ○

Dimensions

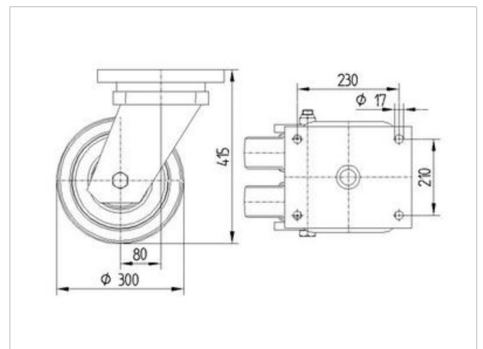

Structure & Mounting

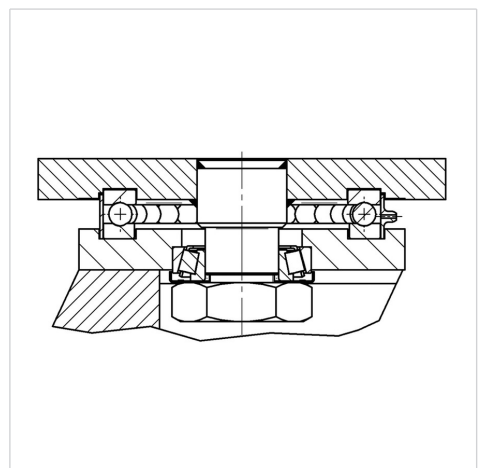

OMIKRON TWIN

9950FTP300P68

EAN 4031582316827



BETTER MOBILITY. BETTER LIFE.

Structure & Mounting

