

OMIKRON TWIN

9950TOP125P65

EAN 4031582316872

Swivel castor, housing and plate steel-welded, zinc plated, blue passivated, sealed swivel bearing with dual purpose bearing and tapered roller bearing, threaded king pin and locking nut secured, grease nipple, wheel axle with nut, plate fitting. Wheel centre made of Polyamide, heavy duty, precision ball bearing



BETTER MOBILITY. BETTER LIFE.



Picture may differ from original product

Technical Data

Wheel diameter	125 mm
Wheel width	50 mm
Castor width	189 mm
Size of Plate	200 x 160 mm
Plate hole centres	160 x 120 mm
Plate hole	15 mm
Dome-Ø	160 mm
Offset	50 mm
Swivel Interference	246 mm
Overall height	205 mm
Temperature	- 40 / + 85 °C
Standard	EN 12533
Weight	11.961 kg
Swivel Radius	123 mm
Hardness of tread	Shore D 75
Load capacity	1680 kg
Load capacity (static)	3360 kg

Advantages at a glance

Roll performance	● ● ● ● ●
Movement noise	● ● ● ○ ○
Attrition	● ● ● ● ●
Corrosion resistance	● ● ● ○ ○

Dimensions

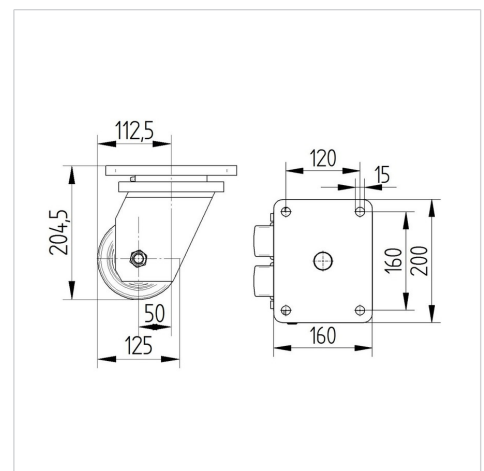

Structure & Mounting

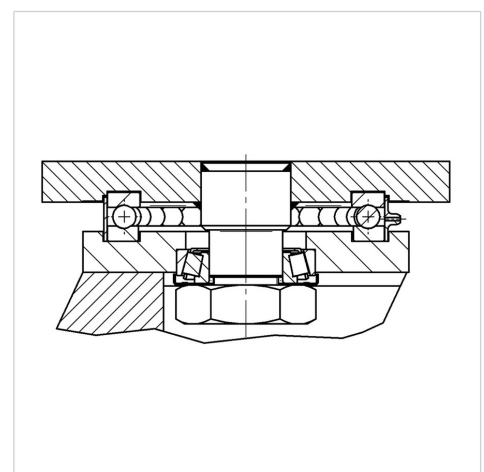

OMIKRON TWIN

9950TOP125P65

EAN 4031582316872



BETTER MOBILITY. BETTER LIFE.

Structure & Mounting

