

SOLUTIONS FOR MECHANICAL ENGINEERING & WORKSHOPS DURABLE, EFFICIENT AND SAFE

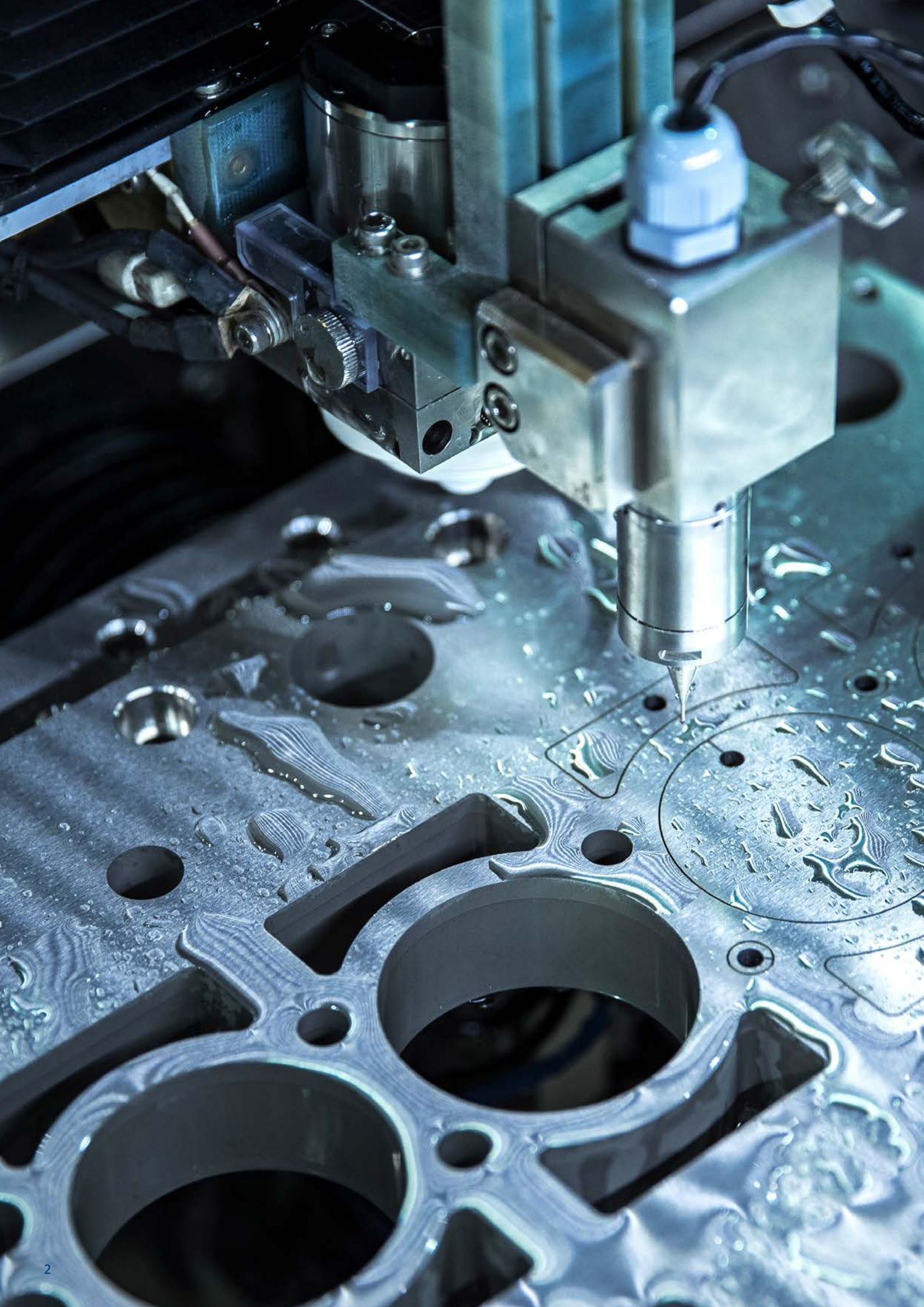

BETTER MOBILITY. BETTER LIFE.



MOBILITY SOLUTIONS OF WEIGHT

In the field of machine and workshop equipment, well-known companies from a wide range of industries rely on our mobility solutions. Thanks to our high level of expertise in heavy industrial castors, we know the special requirements of the various applications and offer a wide range of castors and wheels for rough environments and heavy loads. With our wide range, with many years of experience, and the willingness to help with made to measure intelligent mobility solutions, we are always by your side for national and international projects.

HIGH LOAD CAPACITY AND MAXIMUM SAFETY

Our industrial castors are convincing with high load capacities and are extremely wear-resistant. Solutions with reliable brakes guarantee a safe stance and are ideal for workshop trolleys, transport trolleys, tool trolleys or work platforms. Castors and wheels with central locking ensure convenient and quick locking - for example of waste containers.

Occupational safety plays a major role in our developments. For example, we offer you solutions with safety locking that reliably prevent unintentional rolling movements.

RESISTANT MATERIALS

For applications in the food, pharmaceutical and chemical industries, as well as for many other sensitive areas, we have stainless steel products to choose from.

On the following pages you will find more information about our mobility solutions. Feel free to contact us for further technical details or a personal conversation.

EFFICIENT TRANSPORT WITH E-DRIVE

The smart solution, our electric drive system, also known as the "E-Drive", allows employees to effortlessly transport a large volume of goods and not only improves productivity, but also enhances staff well-being and reduces operating costs.

Practical system solution

Easily integrated system solution consisting of a drive unit, control module, hand-held control unit, battery, charger and mounting set.

High Flexibility

The E-Drive System can be individually configured to suit the user's needs and can also be integrated into existing equipment. When the system is in standby mode, the wheel retracts so the equipment can be moved manually.

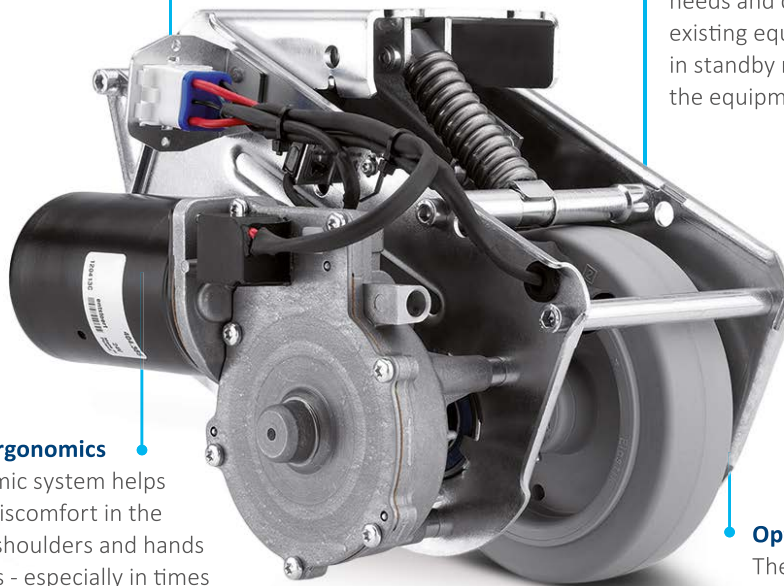

Improved ergonomics

The ergonomic system helps to prevent discomfort in the neck, back, shoulders and hands among users - especially in times of high demographic change. Ergonomic handling and operation means fewer absences due to illness, allowing a quick regain of the initial cost of the E-Drive system.

Optimised productivity

The E-Drive helps to make operating processes more efficient and results in reduced costs.



"From our point of view as a user, the flexible and easily controllable E-Drive solution provided by TENTE fits very well into our Kaizen approach."

Axel Zühlke, Director Logistics at Esselte Leitz

Read more about the customer reference:
www.tente.com/esselte-leitz

INCREASED PRODUCTIVITY WITH DELTA

 **300 - 600 kg**  **178 - 250 mm**  **125 - 200 mm**

Due to the precision ball bearing, the Delta has good running and swivel properties, so that easy manoeuvring is possible and little effort is required. Additional directional locking devices also ensure improved driving stability.



PROPERTIES OF THE DELTA SWIVEL HEAD

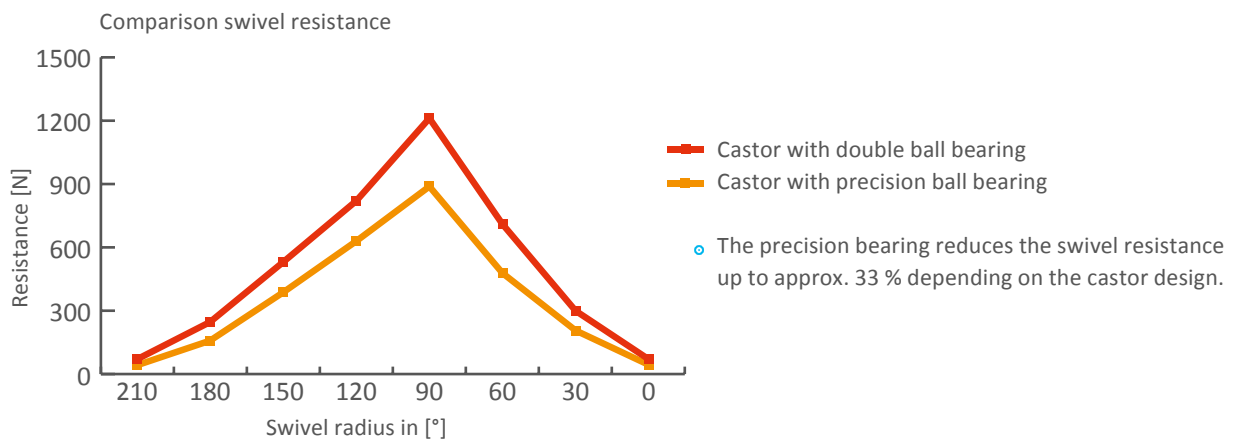

LOW MAINTENANCE COSTS WITH ZETA

 **300 - 800 kg**  **164 - 290 mm**  **125 - 250 mm**

Hardened bearing covers ensure low wear. Maintenance costs are significantly reduced due to the robust, low-maintenance design. With its high performance and high load capacity, thanks to heavy sheet steel, Zeta is the perfect solution for many applications.

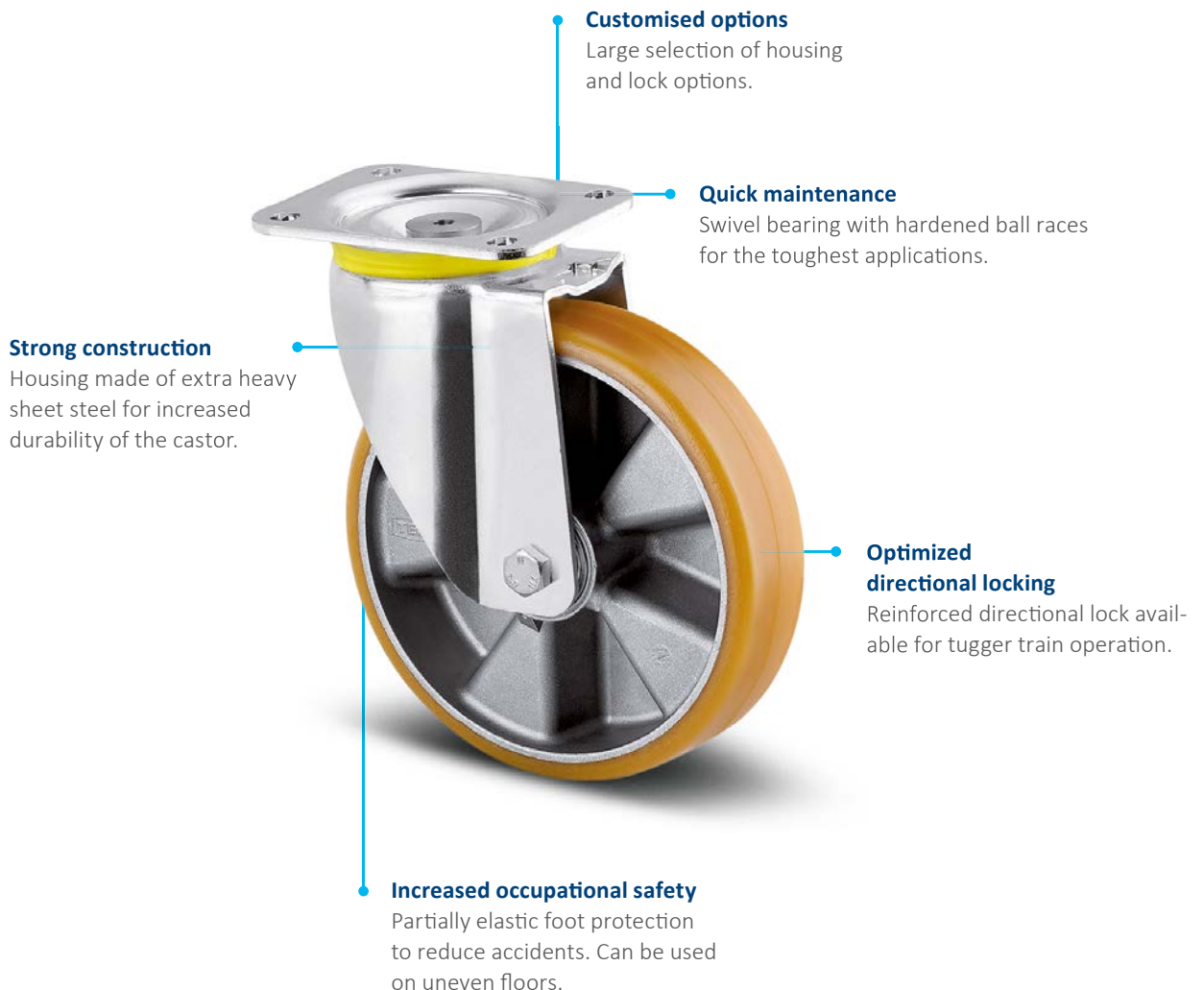

ENHANCED ERGONOMICS WITH LINEA LOAD

📏 120 - 150 kg 🛞 125 - 170 mm 🌀 100 - 150 mm

The Linea twin wheel castor has an extremely low swivel resistance for easy manoeuvrability with little physical effort. The heavy duty castor with extremely low overall height reduces the risk of accidents. The Linea castor can be adapted to any application and is also available in an electrically conductive version.



SAFE WORKING PROCESSES WITH ALPHA SAFETY

 **200 - 400 kg**  **200 - 240 mm**  **160 - 200 mm**

Our Alpha safety with automatic locking system can only be moved if the user keeps the operating handle pressed. When the handle is released, the castors are automatically locked and the working platform is instantly brought to a safe stance.



Practical system solution
We offer a practical system solution with all technical components.

Ergonomic use
The handle for releasing the lock can be at a height that is easily accessible and convenient to operate.

Easy to move
Thanks to the excellent running characteristics of the castor, it can be pushed effortlessly over long distances.

Reduced accident risk
Optimum force required to operate the handle to prevent accidents.



"TENTE Alpha safety is a solution with built-in workplace safety."

Yves Héroumont, Technical Service, SNCB

Read more about the customer reference:
www.tente.com/sncb



Pericolo: non spingere
e non affluire per non causare
incidenti.
Dopo l'operazione
verificare lo stato di carica.

STOKYEM

INCREASED SAFETY WITH FOOT PROTECTION

🌀 125 - 250 mm*

With the foot protection system from TENTE you avoid accidents at work and ensure the highest level of workplace safety. The flexible rubber guards can also be used on uneven floors and therefore ensure problem-free transport.



Protects employees
The foot guard prevents any contact between the foot and wheel.

Flexible use
Suitable for flat and uneven floors, as well as for driving over ramps and barriers at an incline of 15°.

Retrofittable
The adapted fork from our Delta, Zeta and Kappa product family allows a fast and uncomplicated retrofit.

Flexible rubber
The flexible rubber guards are shaped in such a way that they are pressed in towards the wheel as soon as the wheel comes into contact with the foot. This prevents the castor from moving over and crushing the foot.

Robust steel
A rigid guard rail made of steel is attached to the side of the wheel. This ensures that the foot is guided safely around the side of the wheel.



Mounted foot guard



"With TENTE's solution we have improved both workplace safety and the protection of our products."

Tobias R ther, Corporate Safety Coordinator for the INTERPANE Group

Read more about the customer reference:
www.tente.com/interpane



OPTIMISED WORKING PROCESSES WITH SCOUT

📏 150 - 350 kg 📏 202 - 245 mm 📏 160 - 200 mm

The Scout is the perfect solution for transport trolleys of driverless transport devices thanks to its space-saving and slim design. As Scout is made from stainless steel, it is washable, and we also offer a version which protects users and devices from electrostatic discharge.

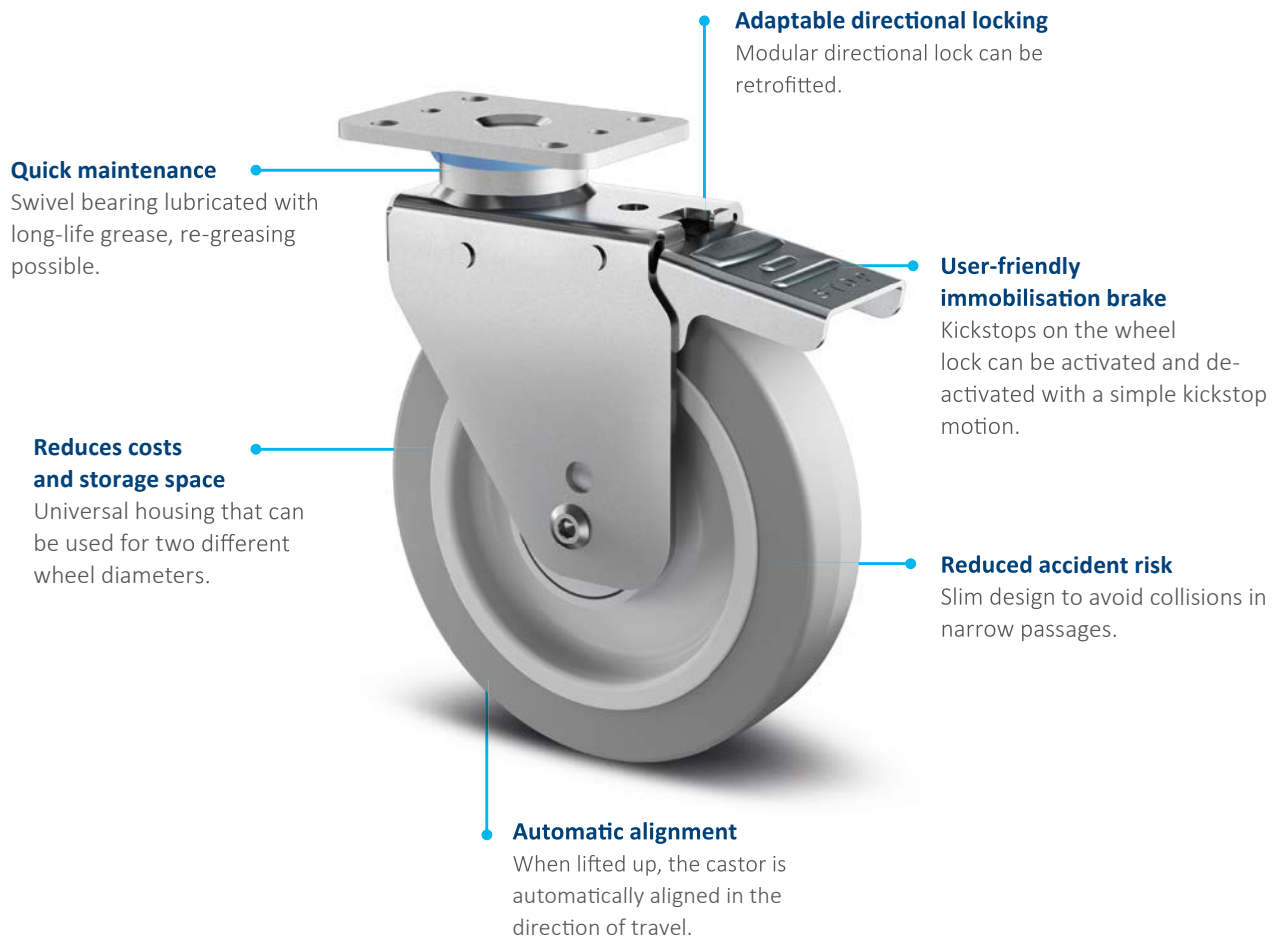

SAFE TRANSPORT WITH KAPPA FLEX

 **360 - 750 kg**  **160 - 200 mm**

With Kappa flex, your goods are transported safely. The spring-loaded housing construction and additionally integrated springs to compensate for uneven ground, result in a system that is perfectly and flexibly suited for every requirement and load.

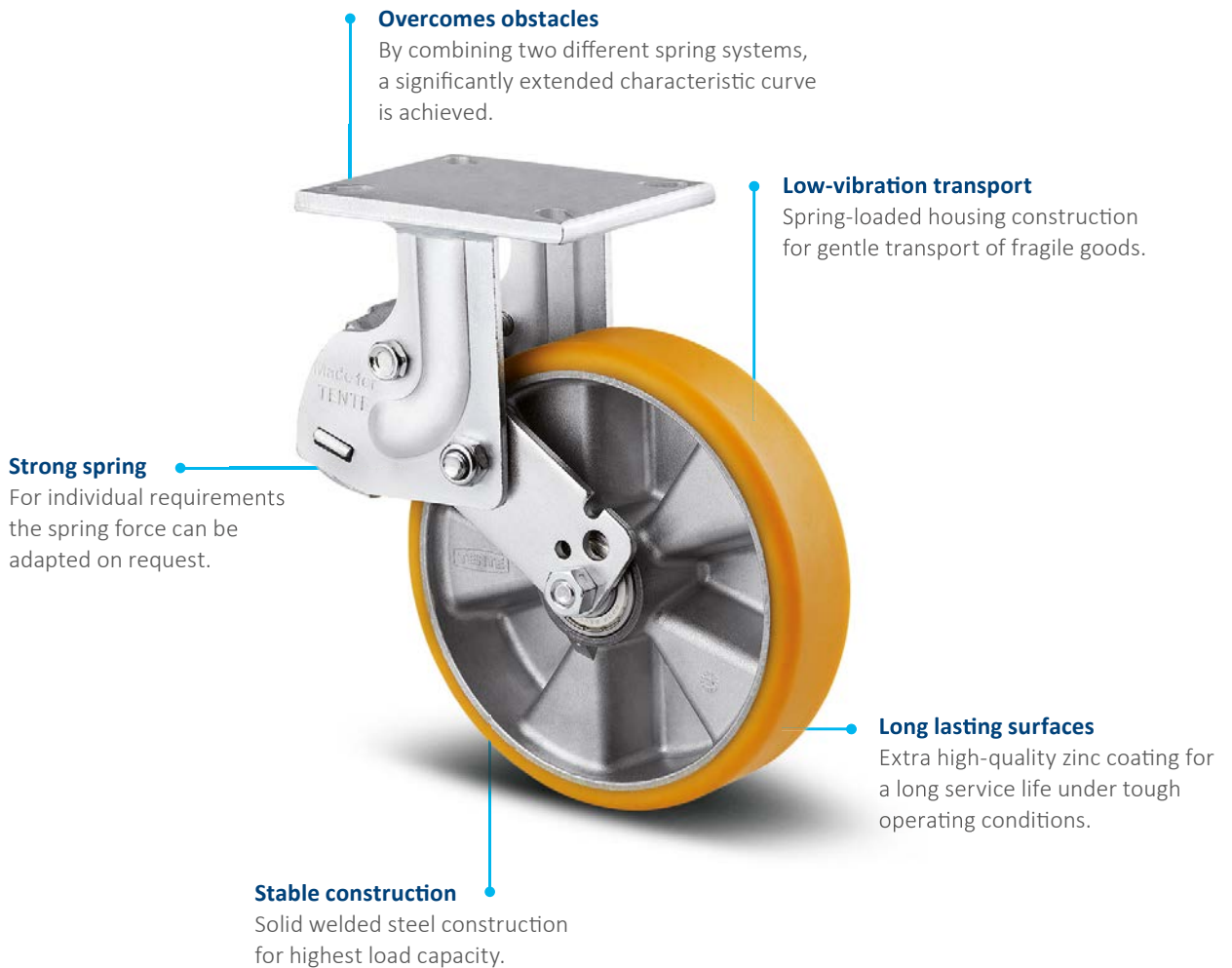

INCREASED PRODUCTIVITY WITH ULTRATECH WHEELS

Outstanding performance due to premium polyurethane. Ideal for applications with heavy loads travelling at high speed in tough working conditions.

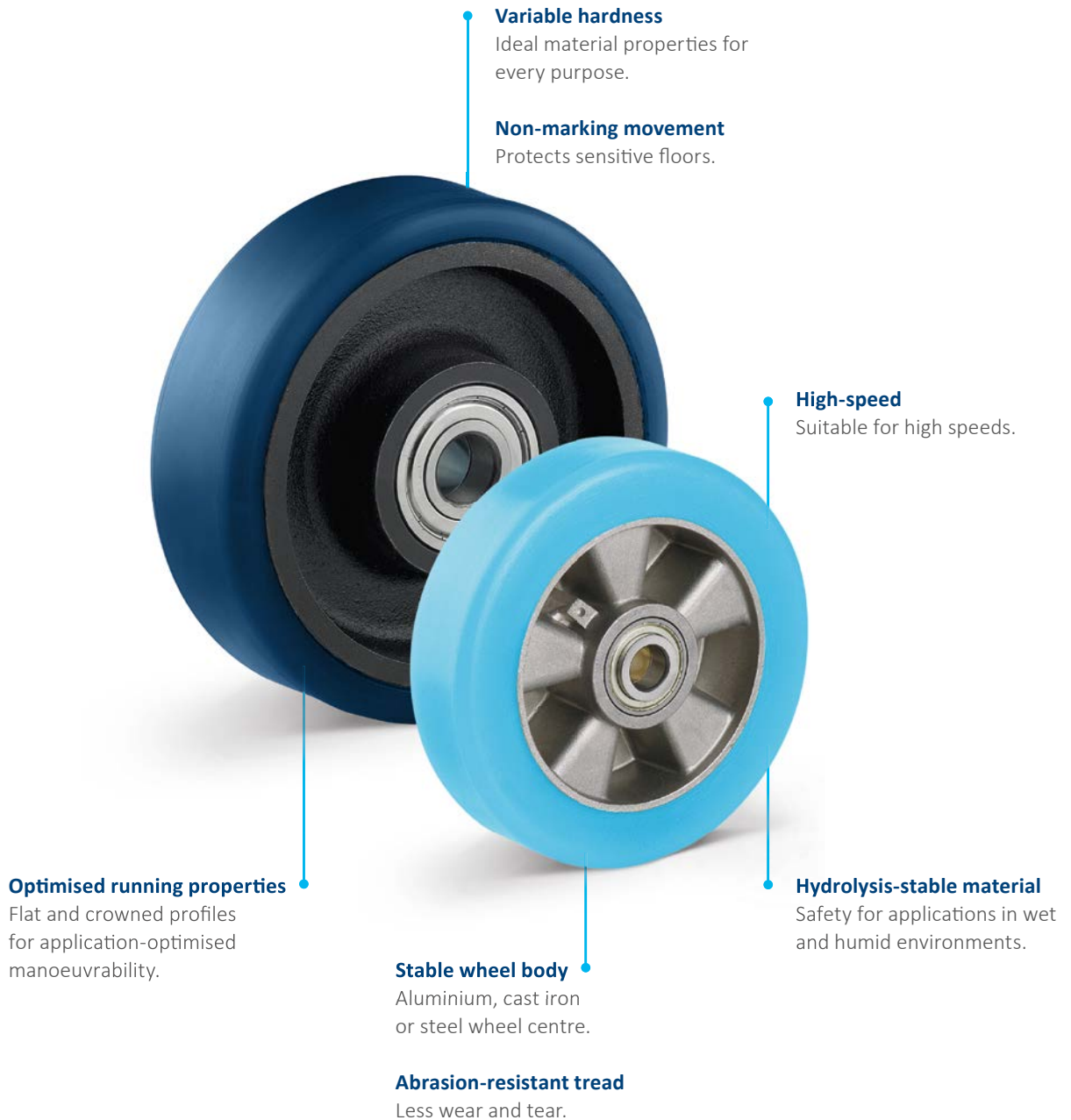

LESS WEAR AND TEAR WITH DURATECH WHEELS

Our robust Duratech wheels are stable and almost indestructible, made of polyamide and duroplastic.



HIGH LOAD CAPACITY WITH NOVATECH WHEELS

Our wheels with Novatech coating are characterized by high cut resistance, low wear and excellent running properties. They are therefore suitable for rough industrial environments as well as for very sensitive areas.

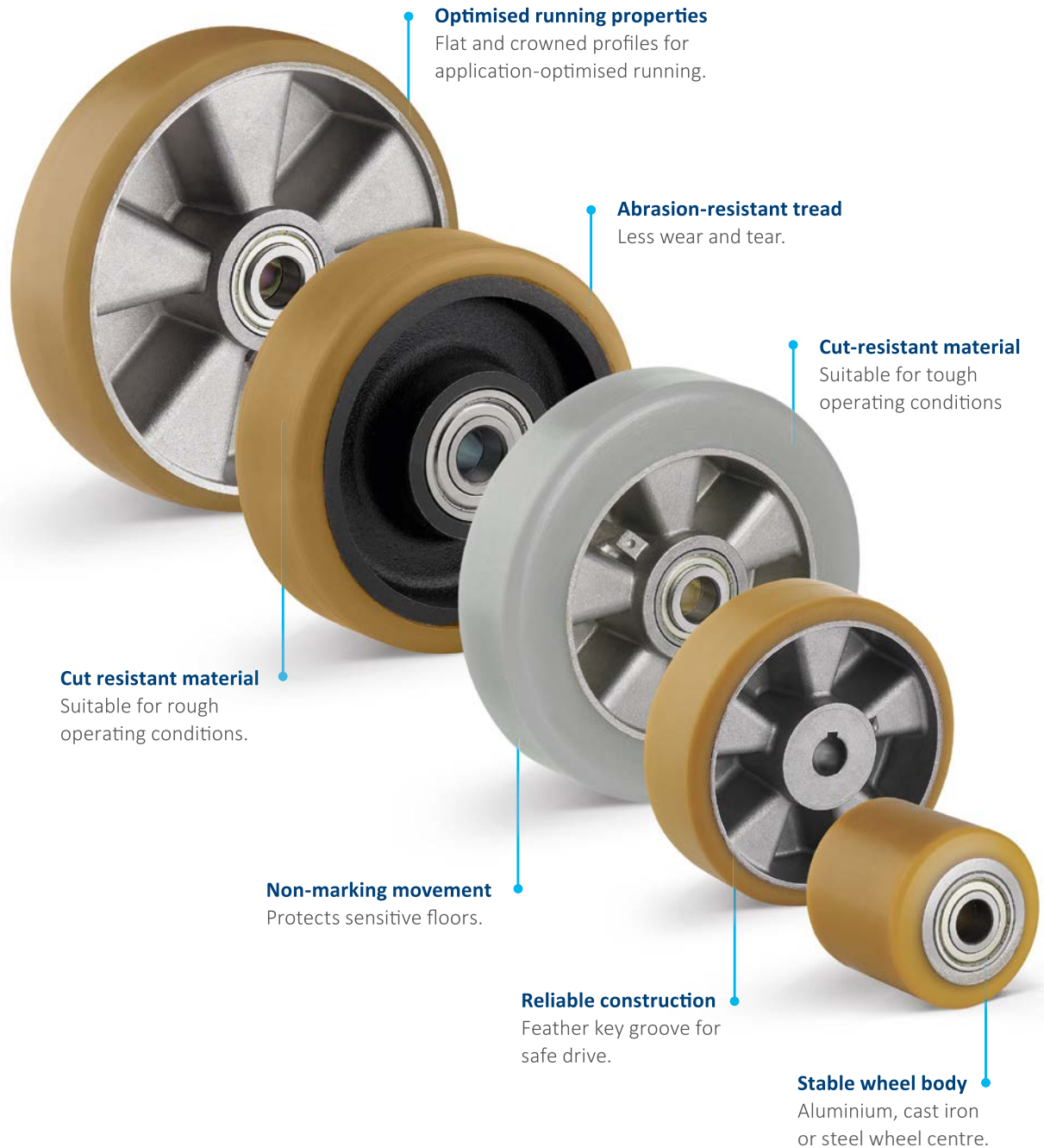

QUIET WORKING ENVIRONMENT WITH ELASTECH WHEELS

Silent runners made of elastic and silicone rubber for maximum driving comfort and to reduce noise emission.

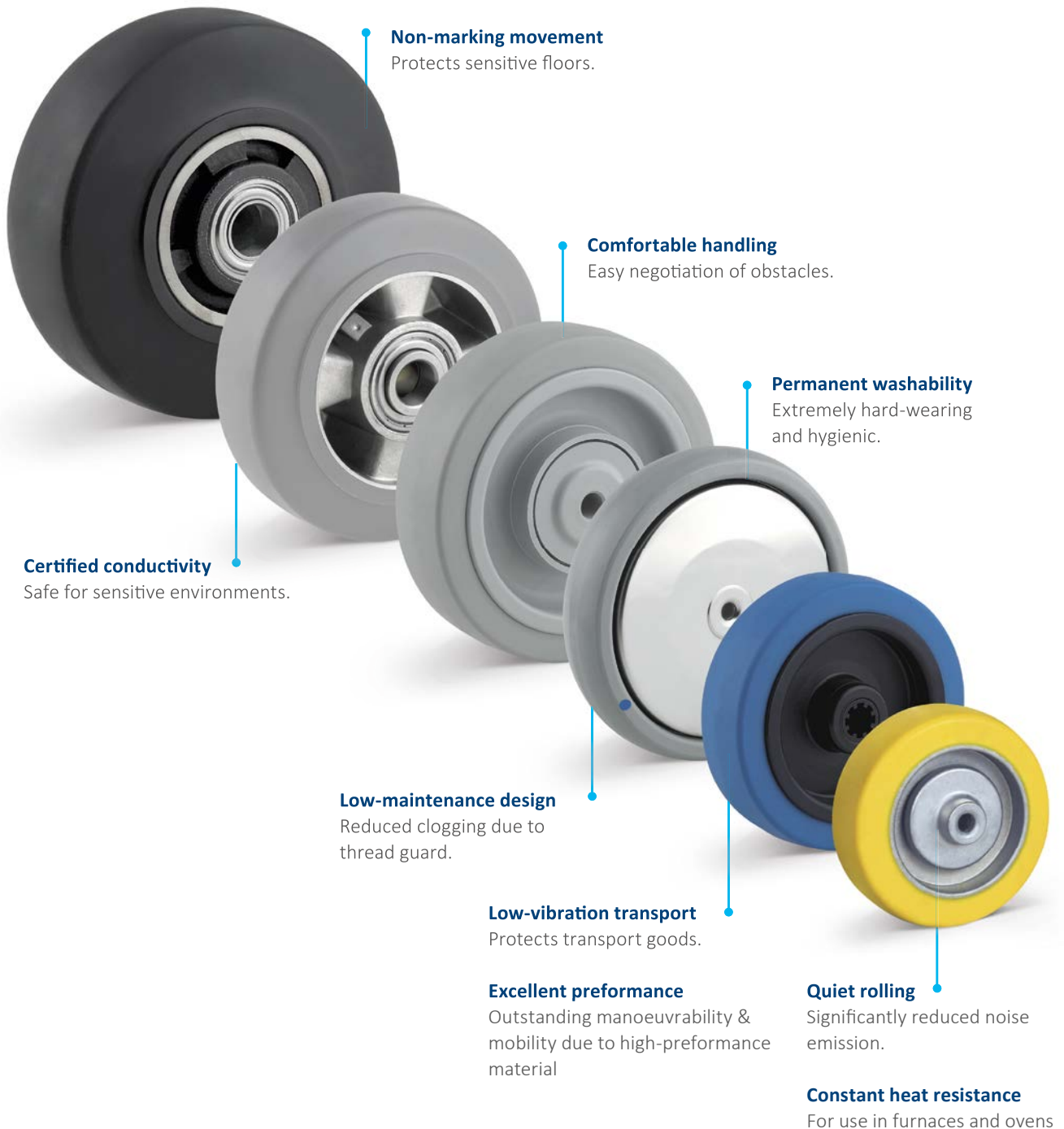

SAVE TIME AND EFFORT WITH CENTRAL LOCKING CASTORS

Using a central operating lever, multiple castors can be locked simultaneously, thereby increasing productivity and reducing the user's workload.

User-friendly
If the lock is mounted on the upper plate, it is accessible from any position.

Flexible mounting
Castor connection is possible using an hexagonal rod.

Secure stance
Centrally locking castors guarantee a secure stance.

Easy modification and exchange
Compatible with all swivel, fixed and locking castors of the same height. Can also be combined with an automatic locking function for greater safety.

Central locking plate

CENTRAL LOCKING POSSIBLE FOR THE FOLLOWING PRODUCT FAMILIES:



Alpha
160 - 350 kg
80 - 125 mm



Delta
540 - 600 kg
160 - 200 mm

WORK MORE EFFICIENTLY WITH SELF-ALIGNING CASTORS

The automatic, spring-loaded directional reset of the castors is real added value for an efficient work process, especially in the field of driverless transport systems. This improves user-friendliness and shortens internal processes, thus increasing productivity.

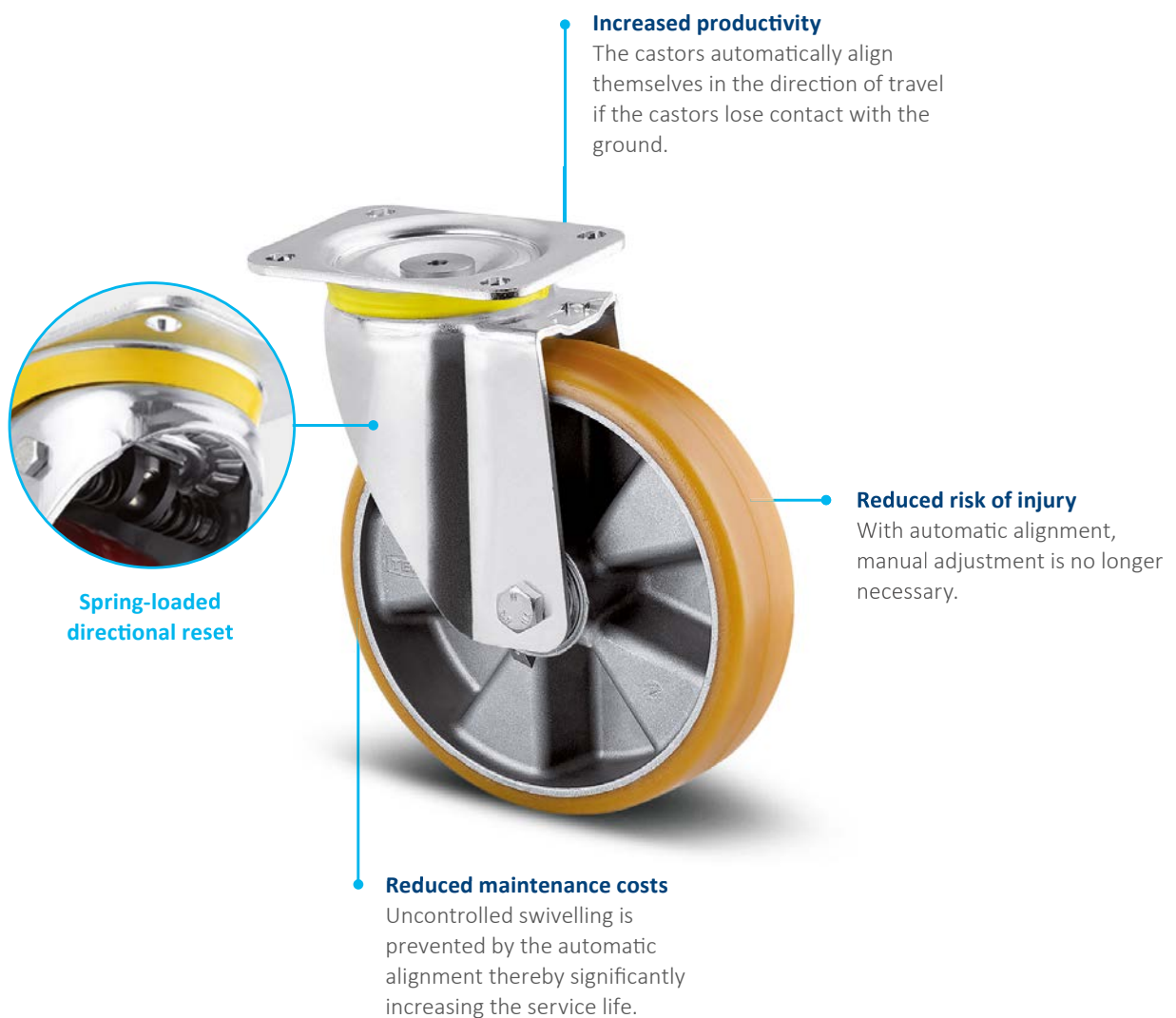

THE SPRING-LOADED DIRECTIONAL LOCK IS ALSO AVAILABLE FOR THE FOLLOWING PRODUCT FAMILIES:



Alpha

160 - 350 kg
80 - 125 mm



Zeta

300 - 800 kg
125 - 250 mm



Scout

150 - 350 kg
160 - 200 mm

DIVERSITY WITH A SYSTEM OUR CASTORS

All of our products have their own specific qualities and strengths. Whether it's high design standards, specialist applications or exceptional load capacities – our range can meet your needs and be adapted to fit different models.

From the correct dimensions and technical specifications to the required configuration, our product families are able to offer the ideal solution – whatever you need. Contact us for more information or visit our website: www.tente.com

E-Drive



⌀ 125 mm

Alpha



⊃ 70 - 500 kg
⌀ 80 - 200 mm

Delta



⊃ 300 - 600 kg
⌀ 125 - 200 mm

Delta twin



⊃ 600 - 750 kg
⌀ 125 - 200 mm

Zeta



⊃ 300 - 800 kg
⌀ 125 - 250 mm

Kappa



⊃ 300 - 2.000 kg
⌀ 80 - 300 mm

Kappa flex



⊃ 360 - 750 kg
⌀ 160 - 200 mm

Omikron



⊃ 900 - 11.000 kg
⌀ 100 - 500 mm

Radiata



1.200 - 1.500 kg
80 mm

Scout



150 - 350 kg
160 - 200 mm

Integral



100 - 150 kg
100 - 200 mm

Integral twin



125 - 250 kg
100 - 150 mm

Linea clinic



150 - 200 kg
125 - 150 mm

Aviana care



100 kg
75 mm

Aviana



75 mm

Agila



40 - 100 kg
50 - 150 mm

Agila twin



50 - 100 kg
50 - 75 mm

Stora



60 - 160 kg
75 - 160 mm

Mono



30 - 70 kg
50 - 100 mm

Galea



60 - 100 kg
100 - 125 mm

Levina



60 - 100 kg
75 - 150 mm

Linea



40 - 150 kg
50 - 150 mm

Anika



40 - 50 kg
55 - 75 mm

Lumina



30 - 100 kg
35 - 75 mm

Stylea



40 - 100 kg
35 - 100 mm

Smiles



40 kg
50 mm

Compacta



10 - 55 kg
14 - 50 mm

EXPERTISE THAT INSPIRES

CONTACT US

We are a globally operating company supporting you on five continents. This means on-site support with service on a level playing field – along with in-depth knowledge. Additionally, our solution experts will advise you on the best mobility concept for your needs. Go here to find your nearest TENTE location: www.tente.com/locations

INCREASE YOUR EFFICIENCY

Our intelligent mobility solutions help you save time, effort, energy, and operating expenses. This allows you to improve your operating methods and working conditions, thereby optimising your processes and ensuring higher productivity, profitability and safety. Ask for our solutions catalogue or read about how our customers benefit from our tailor-made solutions on our website: www.tente.com/solutions

SAVE DEVELOPMENT TIME

On our website you will find technical drawings, product data sheets and 2D and 3D CAD files in various formats: www.tente.com/products

GET MORE INFORMATION

In addition to our informative website, you can easily download various catalogues and brochures on mobility solutions, customer references, and much more: www.tente.com/download



ER LIFE.

ET



www.tente.com



PRODUCTIVITY



SAFETY



DESIGN



DURABILITY



ENVIRONMENT